

Instrumentation Tube Fittings



Greetings

We, Union Metal as her registered brand Uni-Lok, founded in 1984, have been specialized in the design and manufacture of high performance “Double Ferrule Compression Type Tube Fittings”. and “Instrumentation Valves”.

Thanks to our outstanding capacity for innovation and our policy of investment in Research and Development as well as Quality Controls, Uni-Lok has been able to capitalize on our expert knowledge, oriented towards the new expectations of the customers worldwide in the industrial, petro-chemical, offshore, ship building, power plant and environmental fields.

Our well-trained staff feels that we are providing our customers the absolute best service and that service is backed up by our Performance Guarantee.
Systematic Controls is committed to utilizing the latest technological and informational advancements to provide our customers with maximum support.

Sincerely Yours,

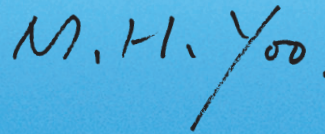

Myoung-Ho Yoo
C.E.O.

Greetings

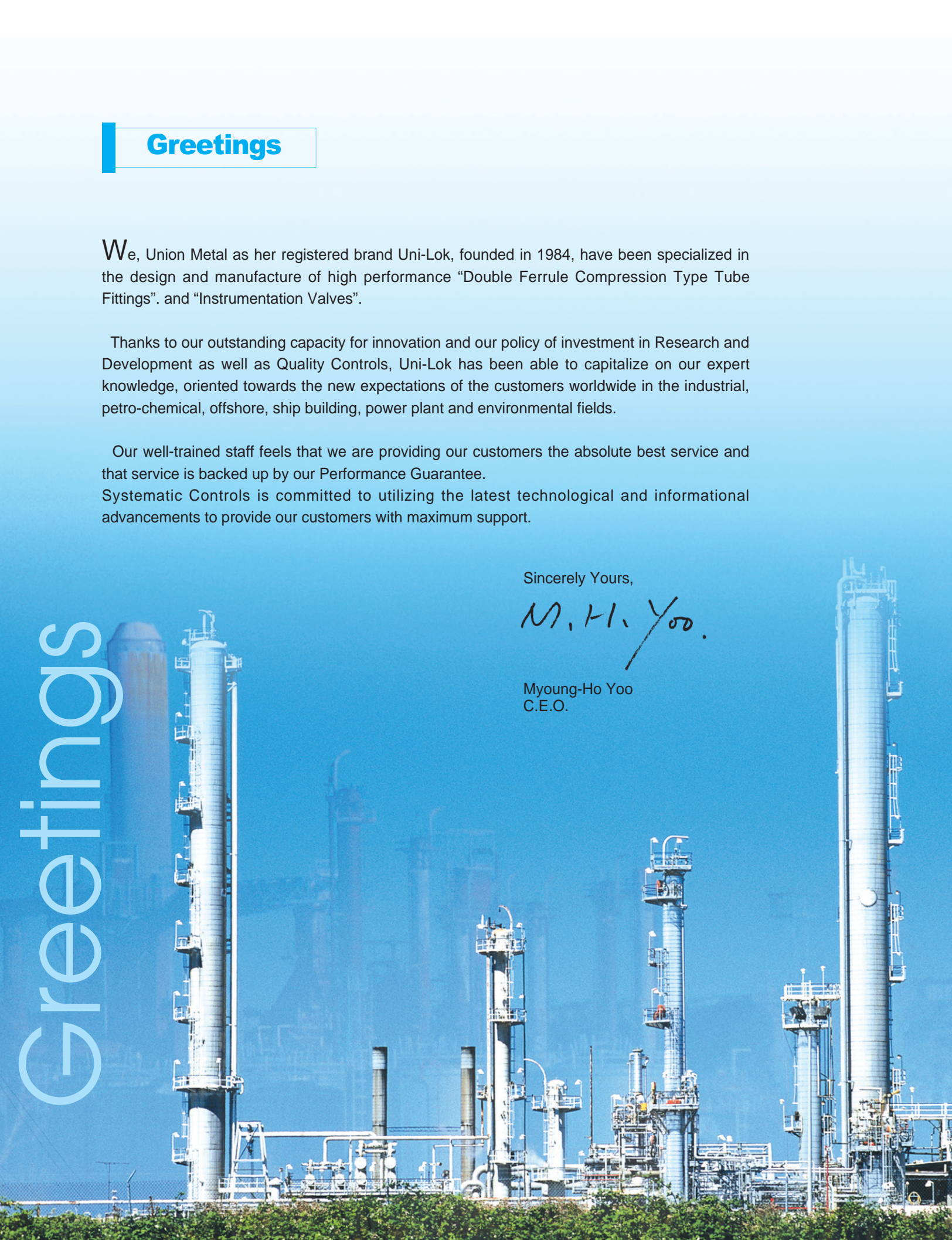

Features

Gaugeability

Uni-Lok tube fittings & valves are produced in accordance with the exacting tolerance. Without such close tolerance, the interaction of the Nut, the Ferrules and the Body would not be interacted properly.

허용공차에 대한 철저한 관리를 하지 않으면, Ferrule, Nut 및 Body의 상호 보완 작업을 수행할 수 없어, 모든 Uni-Lok 제품은 정확한 허용공차로 가공됩니다.

Interchangeability

Uni-Lok tube fittings can be interchanged with the most of tube fittings that are manufactured by the international standard.

모든 Uni-Lok 제품은 국제적 규격에 의해 제작되므로 대부분의 세계적인 제품과 상호 호환성이 있습니다.

Corrosion Resistance

Uni-Lok tube fittings are performed by repeated tests and are already approved by various industrial areas. Our ferrules have the strongest corrosion resistance because of their special hardening process.

모든 Uni-Lok 제품은 반복적인 실험을 통하여 모든 산업분야에서 품질에 대한 우수성을 인정받았고, 특히 Ferrules에 대한 특수한 열처리 공정으로 내식성이 우수합니다.

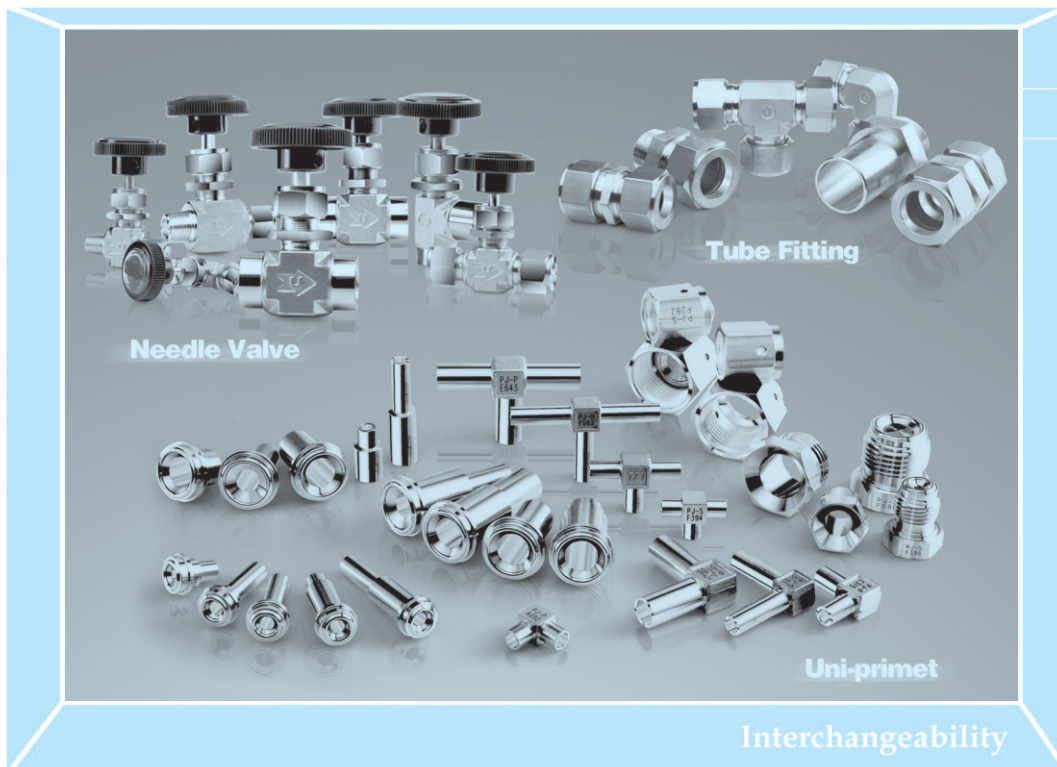

Systematic Quality Control Program

체계적인 품질관리 프로그램

All Uni-Lok fittings and valves have been producing outstanding capacity for design, exact production process and strict quality control system.

Also, Uni-Lok have been widely using where the gas and liquid flows due to its reliability of quality as well as punctual delivery.

We, Uni-Lok, will do our best to meet the customer's requirements with the best quality and service as we have done.

모든 Uni-Lok 제품은 ISO 9001 품질보증 시스템에 의거한 우수한 설계능력, 정밀한 제조 공정 및 엄격한 품질 관리 시스템에 의하여 첨단 설비에서 생산되어 지고 있습니다.

또한 제품의 신뢰성 및 정확한 납기로 기체 및 액체의 흐름이 있는 전 산업분야에서 선택되어 사용되고 있습니다.

앞으로도 Uni-Lok은 최고의 품질, 최상의 서비스 및 끊임없는 연구개발로 고객의 요구에 최선을 다할 것입니다.

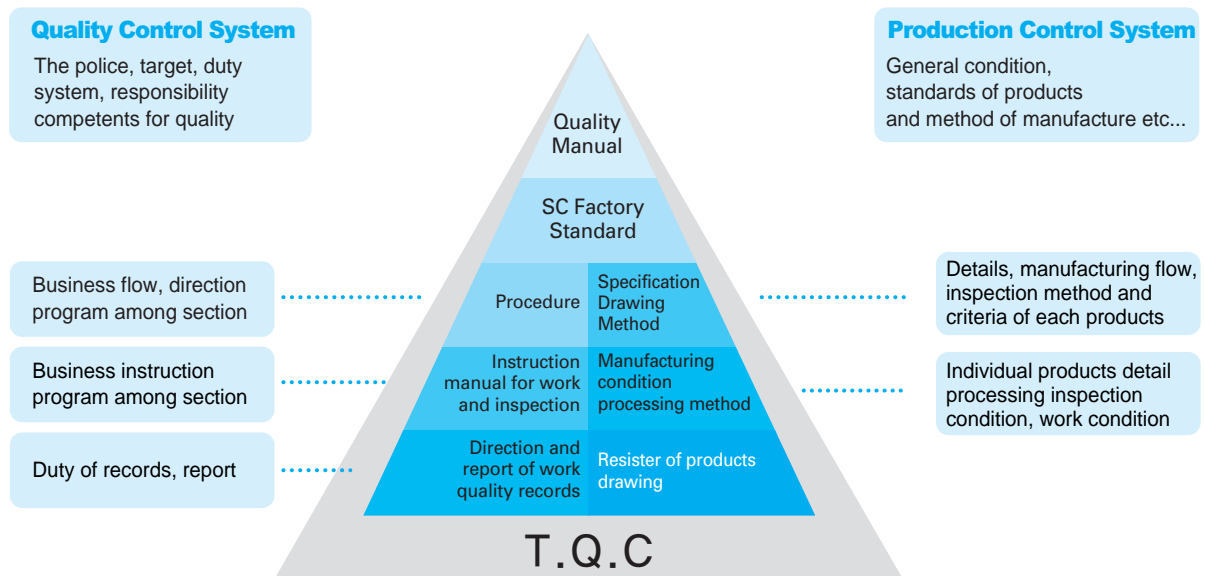

Assembly Instructions

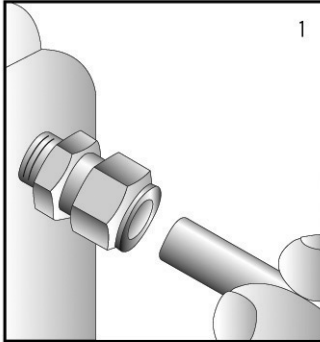

1. Uni-Lok tube fittings, insert front and back ferrule, are sold completely assembled and ready for directly use. Easily insert the tube into the center of nut until it bottoms in the fitting body. (If the fitting is disassembled, please note that small tapered end of the ferrule goes into the fitting body.)

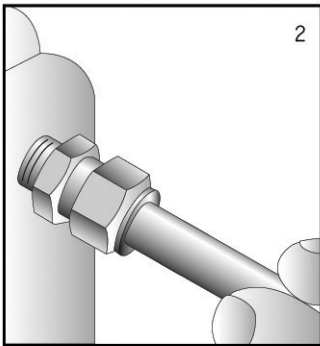

2. Tighten nut as much as you can by finger this is call "finger tight." Then tight nut with wrench an additional 1-1/4 turn indicated as shown. Hold fitting body with a second to prevent body from turning. It is helpful to mark the nut to facilitate counting the number of turns.

Size 1/4" thru 1"
Size M06 thru M25
(6mm-25mm)

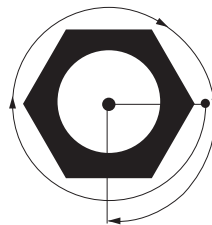

1-1/4 Turns from Finger Tight

Size 1/8" thru 3/16"
Size M03 thru M04
(3mm-4mm)

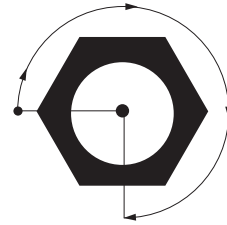

Only 3/4 Turn from Finger Tight is necessary to seal and will result in additional remakes of the fitting

Remake Instructions

1. When repeated assemblies, insert tubing to the preswaged with ferrule and nut into fitting body.
2. Finger tighten the ferrule, nut and further tighten the nut with a wrench to the oriinal position keeping the body steady with a back-up wrench.
3. When a sharp rise in resistance will be felt at the original position. The sung-up slightly with a wrench.

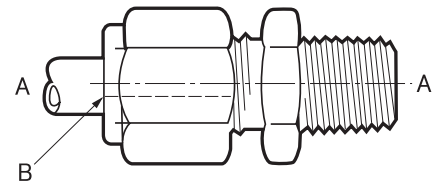

NOTE : All assembled fittings in this catalog are shown in the Finger Tight Position

Most important, only 1-1/4 turns are required. If over tightening, as this could lead to leakage or tube blow-out under pressure. Additional 3/4 turn for size 3mm O.D through 4mm O.D.

Fitting 연결시 NUT를 1-1/4 회전하는 것이 가장 적당한 조임이며 더 이상의 무리한 조임은 Ferrule에 손상을 줄뿐만 아니라 Fitting이 파손되므로 누설의 원인이 됩니다. (외경 3mm~4mm Fitting은 3/4 회전)

Tube Fittings

How to Order

Uni-Lok Tube Fittings are ordered by part number as shown Index.

Size : Tube and pipe thread size are designated by the number of sixteenths of an inch and metric size.

Type : A letter or combination of letters and numbers are used to designate the type of fittings.

Material : Basic material type (SS = 316SS, B=Brass)

Nomenclature for Fractional Tube



Tube O.D.
(1/2")

Uni-Lok

Fitting Type
(Male Connector)

Pipe Size
(1/4")

Thread Type
(NPT)

Material
SS = 316 Stainless Steel
BS = Brass
CS = Carbon Steel
MO = Monel
IN = Inconel

Tube O.D. Designations

Tube O.D.	inch	1/8	3/16	1/4	5/16	3/8	1/2	5/8	3/4	7/8	1
	mm	3.17	4.76	6.35	7.93	9.52	12.70	15.87	19.05	22.22	25.40
Designation		02	03	04	05	06	08	10	12	14	16

Pipe Size Designations

Nom. Size	1/8	1/4	3/8	1/2	3/4	1
Designation	02	04	06	08	12	16

Thread Designation

N : American National Standard Taper Pipe Threads(NPT : ANSI B1. 20. 1)
R : Taper Pipe Threads(PT : JIS B0203, ISO 7/1)
G : Parallel Pipe Threads(PF : JIS B0202, ISO 228/1)

Nomenclature for Metric Tube



Metric Tube Fittings

Tube O.D.
(12mm)

Uni-Lok

Fitting Type
(Male Connector)

Pipe Size
(1/4")

Thread Type
(PT)

Material
SS = 316 Stainless Steel
BS = Brass
CS = Carbon Steel
MO = Monel
IN = Inconel

Tube O.D. Designations

Tube O.D	3	4	6	8	10	12	15	16	18	20	22	25
Designation	M03	M04	M06	M08	M10	M12	M15	M16	M18	M20	M22	M25

Example for Fitting Size

Identifier	Tube O.D.	PT or Tube O.D	Identifier	Tube O.D.	PT or Tube O.D	Identifier	Tube O.D.	PT or Tube O.D
02□-02	1/8	1/8	05□-02	5/16	1/8	08□-08	1/2	1/2
02□-04	1/8	1/4	05□-04	5/16	1/4	08□-12	1/2	3/4
02□-06	1/8	3/8	05□-06	5/16	3/8	10□-08	5/8	1/2
02□-08	1/8	1/2	06□-02	3/8	1/8	10□-12	5/8	3/4
03□-02	3/16	1/8	06□-04	3/8	1/4	12□-08	3/4	1/2
03□-04	3/16	1/4	05□-06	5/16	3/8	12□-12	3/4	3/4
04□-02	1/4	1/8	05□-08	5/16	1/2	12□-16	3/4	1
04□-04	1/4	1/4	05□-12	5/16	3/4	14□-12	7/8	3/4
04□-06	1/4	3/8	06□-02	3/8	1/8	16□-08	1	1/2
04□-08	1/4	1/2	08□-04	1/2	1/4	16□-12	1	3/4
04□-12	1/4	3/4	08□-06	1/2	3/8	16□-16	1	1

Thread Information

Threads of many kinds are used for different purposes in small piping components. The followings are the more common types of pipe threads.

1. NPT Tapered Pipe Threads

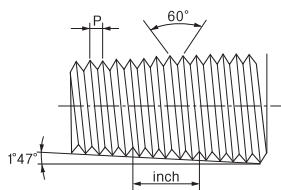

- 60° Thread Angle
- Taper Angle 1° 47'
- Truncation of root and crest are flat.
- Pitch measured in inches.

NPT(National Pipe Tapered) is made to specifications outlined in ANSI B1. 2. This is the pipe thread used on the pipe end.

2. ISO 7/1 Tapered Pipe Threads

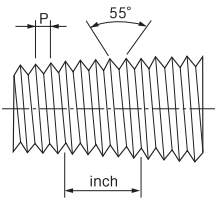
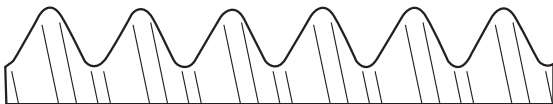

- 55° Thread Angle
- Taper Angle 1° 47'
- Truncation of root and crest are round.
- Pitch measured in millimeters.

International Organization for Standards(ISO 7/1) Tapered.(P.T) ISO tapered threads are equivalent to DIN 2999. BSP TR, JIS B0203, R 1/8 and R 1/4 Keg.

In application ISO threads are used similar to NPT threads. However, care should be used that ISO and NPT threads are not mixed. ISO threads have a 55° angle versus 60° for NPT. Thread pitch is usually measured in millimeters but may be expressed in inch. In many sizes the threads-per-inch are different and the root and crest configurations are different from NPT.

3. ISO 229/1 Parallel Pipe Threads

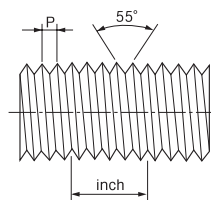
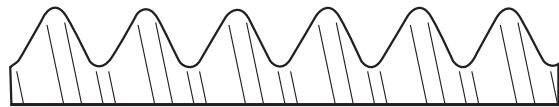

- 55° Thread Angle
- Diameter measured in inches.
- Truncation of root and crest are round.
- Pitch measured in inches.

International Organization for Standards(ISO 228/1) parallel(PF) ISO Parallel threads are equivalent to DIN ISO 228/1, BSP PL, JIS B0202, R 1/8 and R 1/4.

These pipe threads are similar in configuration to 7/1 threads except there is no taper. Therefore do not work by thread interference like the tapered pipe threads of ISO 7/1 or NPT. A gasket or O-Ring is normally used to seal into the parallel female threaded component.

Comparison Chart Pipe Threads

Nominal Size	Threads Per inch	Included Thread Angle	Pitch	Pipe O.D.
1/16"	NPT 27	60°	.037"	.312"
	ISO 28	55°	.036"	.312"
1/8"	NPT 27	60°	.037"	.405"
	ISO 28	55°	.036"	.398"
1/4"	NPT 18	60°	.0556"	.540"
	ISO 19	55°	.053"	.535"
3/8"	NPT 18	60°	.0556"	.675"
	ISO 19	55°	.053"	.672"
1/2"	NPT 14	60°	.0714"	.840"
	ISO 19	55°	.071"	.843"
3/4"	NPT 14	60°	.0714"	1.050"
	ISO 14	55°	.071"	1.060"
1"	NPT 11-1/2	60°	.087"	1.315"
	ISO 11	55°	.091"	1.331"
1-1/4"	NPT 11-1/2	60°	.087"	1.660"
	ISO 11	55°	.091"	1.669"
1-1/2"	NPT 11-1/2	60°	.087"	1.315"
	ISO 11	55°	.091"	1.331"
2"	NPT 11-1/2	60°	.087"	1.660"
	ISO 11	55°	.091"	1.669"

Tube Information

Proper tubing selection is essential to the performance of a tubing system. Consider a system's pressure, flow, temperature, environment and compatibility with the process fluids when choosing the tubing material, size and wall thickness.

Wall Thickness

The wall thickness selection should be based on the operating pressure, temperature and shock conditions. Fully annealed tubing is recommended Stainless Steel Tubing having a hardness of less than Rockwell Rb90 should be used.

Cold Drawn Tube A213 and A271

O.D 1-1/2" and under Over 20% Under 0%

Cold Drawn Tube A269

O.D Less than 1/2" Over and Under 15%
1/2" to less than 8" Over and Under 10%

Cold Drawn Pipe A312 and A376

O.D All size Under 12.5%

Seamless Stainless Steel Tubes

Grades in regular production to ASTM A269 : TP304, TP304L, TP316, TP316L, TP321, TP347

Grades in regular production to ASTM A213 : As stated for A269 plus TP304H, TP316H, TP321H, TP347H, TP310S.

Other grades are available on application.

The weights shown in this table theoretical and provided only as a guide.

Cold Drawn

		SWG Gauge Wall Thickness								BWG Gauge Wall Thickness							
		22	20	18	16	14	12	11	10	22	20	18	16	14	12	11	10
Outside Diameter		mm	mm	mm	mm	mm	mm	mm	mm	mm	mm	mm	mm	mm	mm	mm	mm
		0.711	0.914	1.219	1.626	2.032	2.642	2.948	3.251	0.711	0.889	1.245	1.651	2.108	2.769	3.048	3.40
		inches	inches	inches	inches	inches	inches	inches	inches	inches	inches	inches	inches	inches	inches	inches	inches
		0.028	0.036	0.048	0.064	0.080	0.104	0.116	0.128	0.028	0.035	0.049	0.065	0.083	0.109	0.120	0.134
inches	mm	kg/ft	kg/ft	kg/ft	kg/ft	kg/ft	kg/ft	kg/ft	kg/ft	kg/ft	kg/ft	kg/ft	kg/ft	kg/ft	kg/ft	kg/ft	kg/ft
		kg/m	kg/m	kg/m	kg/m	kg/m	kg/m	kg/m	kg/m	kg/m	kg/m	kg/m	kg/m	kg/m	kg/m	kg/m	kg/m
1/4 .250	6.350	0.030	0.038	0.047	0.058	0.067				0.030	0.037	0.048	0.059	0.068			
		0.100	0.124	0.156	0.191	0.219				0.100	0.121	0.158	0.193	0.223			
5/16 .313	7.938	0.039	0.049	0.062	0.078	0.091	0.106			0.039	0.048	0.063	0.079	0.094			
		0.128	0.160	0.204	0.256	0.300	0.349			0.128	0.156	0.208	0.259	0.307			
3/8 .375	9.525	0.048	0.060	0.077	0.098	0.116	0.138	0.147		0.048	0.058	0.078	0.099	0.119	0.142	0.150	
		0.156	0.196	0.252	0.320	0.379	0.453	0.483		0.156	0.191	0.257	0.324	0.389	0.466	0.492	
1/2 .500	12.700	0.065	0.082	0.106	0.137	0.165	0.202	0.218	0.233	0.065	0.080	0.108	0.139	0.170	0.209	0.223	0.240
		0.212	0.268	0.349	0.449	0.540	0.662	0.716	0.765	0.212	0.262	0.355	0.454	0.556	0.685	0.733	0.788
5/8 .625	15.875	0.082	0.104	0.136	0.176	0.214	0.265	0.289	0.312	0.082	0.101	0.138	0.178	0.220	0.276	0.297	0.322
		0.269	0.341	0.445	0.578	0.701	0.871	0.949	1.02	0.269	0.332	0.454	0.585	0.723	0.904	0.974	1.06
3/4 .750	19.050	0.099	0.126	0.165	0.215	0.263	0.329	0.360	0.390	0.099	0.123	0.168	0.218	0.271	0.342	0.370	0.404
		0.325	0.413	0.541	0.706	0.861	1.08	1.18	1.28	0.325	0.402	0.552	0.716	0.890	1.12	1.21	1.33
7/8 .875	22.225	0.116	0.148	0.194	0.254	0.312	0.393	0.431	0.468	0.116	0.144	0.198	0.258	0.322	0.409	0.444	0.486
		0.381	0.485	0.638	0.834	1.02	1.29	1.41	1.54	0.381	0.472	0.651	0.846	1.06	1.34	1.46	1.60
1 1.000	25.400	0.133	0.170	0.224	0.294	0.361	0.457	0.502	0.547	0.133	0.165	0.228	0.298	0.373	0.476	0.517	0.568
		0.437	0.557	0.734	0.963	1.18	1.50	1.65	1.79	0.437	0.543	0.750	0.977	1.22	1.56	1.70	1.87
1-1/4 1.250	31.750	0.168	0.214	0.283	0.372	0.458	0.584	0.644	0.703	0.168	0.208	0.288	0.377	0.474	0.609	0.664	0.733
		0.550	0.702	0.927	1.22	1.50	1.92	2.11	2.31	0.550	0.683	0.946	1.24	1.56	2.00	2.18	2.40
1-1/2 1.500	38.100	0.202	0.258	0.341	0.450	0.556	0.711	0.786	0.860	0.202	0.251	0.348	0.457	0.576	0.743	0.811	0.897
		0.662	0.847	1.12	1.48	1.83	2.33	2.58	2.82	0.662	0.824	1.14	1.50	1.89	2.44	2.66	2.94
1-3/4 1.750	44.450	0.236	0.302	0.400	0.529	0.654	0.839	0.928	1.02	0.236	0.294	0.408	0.537	0.678	0.876	0.958	1.06
		0.775	0.991	1.31	1.73	2.15	2.75	3.05	3.34	0.775	0.965	1.34	1.76	2.22	2.87	3.14	3.48
2 2.000	50.800	0.270	0.346	0.459	0.607	0.752	0.966	1.07	1.17	0.270	0.337	0.468	0.616	0.779	1.01	1.11	1.22
		0.887	1.14	1.51	1.99	2.47	3.17	3.51	3.85	0.887	1.11	1.54	2.02	2.56	3.31	3.63	4.02

Maximum Allowable Working Pressure Table

Working pressure calculated in accordance with ASME B31.3, Chemical, Petrochemical Plant and Refinery Piping Code 1993 Edition.

The Uni-Lok Tube Fittings are rated to maximum working pressure of tubing as shown under table.

Most important, should be selected high quality tubing when installing leak-free and safe systems.

Stainless Steel Tubing

Fully annealed high quality Stainless Steel Seamless Tube to ASTM A-269 or equivalent.

Tubing to be free of scratches, simply for bending and flaring.

Hardness:Rb80 or less.

Tube O.D (inch)	Tube Wall Thickness (inches)																
	0.010	0.012	0.014	0.016	0.020	0.028	0.035	0.049	0.065	0.083	0.095	0.109	0.120	0.134	0.156	0.188	
1/16	5500	6800	8000	9300	11500												
1/8						8500	10800										
3/16						5300	7000	10200									
1/4						4000	5100	7500	10100								
5/16							4000	5800	7900								
3/8							3300	4800	6500								
1/2							2300	3500	4700	6100							
5/8								2800	4000	5200	5900						
3/4								2400	3300	4200	4900	5800					
7/8								2000	2800	3500	4200	4700					
1									2400	3100	3600	4200	4600				
1-1/4										2300	2700	3200	3500	4100	4800		
1-1/2											2300	2600	3000	3300	4000	4800	
2												2000	2200	2400	2800	3500	

Working Pressure(psi)

※ Allowable Stress of 20,000psi between -30°C(-22°F) and 40°C(104°F)based on ultimate tensile strength to be 74,000psi.

※ For tubing for Gas Service use only tube wall thickness on outside of grey area.

Factors used to determine tubing pressure rating at elevated temperatures.

°C	°F	Copper	316SS	304SS	Monel
90	194	0.80	1.00	1.00	0.88
200	392	0.50	0.96	0.91	0.79
310	590	...	0.85	0.80	0.79
428	600	...	0.79	0.74	0.75
536	660	...	0.76	0.68	...
644	720	...	0.37	0.30	...

Example :

316 Stainless Steel
1/2" O.D. x 0.049WT at 310°C

Allowable Working Pressure :
3500psi x 0.85 = 2975psi

To determine allowable pressure at elevated temperatures, multiply allowable working pressure from Stainless Steel Tubing Copper Tubing.

Copper Tubing

Hardness : Rb 60 or less







Tube O.D (inch)	Tube Wall Thickness (inches)							
	0.028	0.035	0.049	0.065	0.083	0.095	0.109	0.120
1/8	2600	3500						
3/16	1700	2200	3300					
1/4	1300	1600	2400	3400				
5/16		1200	1900	2600				
3/8		1000	1600	2200				
1/2		800	1100	1600	2000			
5/8			900	1200	1500	1800		
3/4			700	1000	1300	1500	1700	
7/8			600	800	1100	1300	1500	
1			500	700	900	1100	1300	1400

※ Allowable Stress of 6000psi between -30°C(-22°F) and 40°C(104°F)based on ultimate tensile strength to be 30000psi.

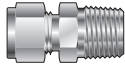

Working Pressure(psi)

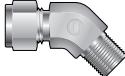
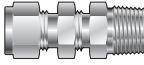
INDEX

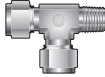
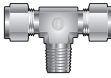
Tube to Male Pipe



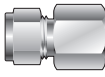
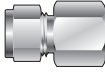

PART	ITEM	Page
Male Connector UMC		12~13
Male Connector for Bonded Seal UMC-G		14
Male Connector for Metal Gasket UMC-M		15
Male Elbow UME		16~17
45° Male Elbow UMVE		18
Bulkhead Male Connector UBMC		18
Thermocouple Male UTMC		18
Male Run Tee UMRT		19
Male Branch Tee UMBT		20

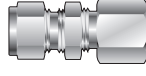
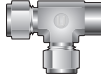
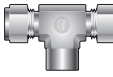
Tube to Female Pipe

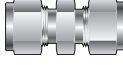
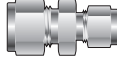
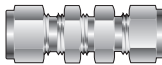

PART	ITEM	Page
Female Connector UFC		21~22
Gauge Connector UGC		23
Female Elbow UFE		24~25

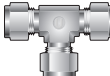
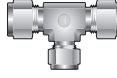
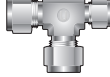
Bulkhead Female Connector UBFC		26
Female Run Tee UFRT		27
Female Branch Tee UFBT		28

Tube to Tube

PART	ITEM	Page
Union UU		29
Reducing Union URU		30~31
Bulkhead Union UBU		32
Union Elbow UEU		33
Union Tee UUT		34
Reducing Union Branch Tee URBT		35
Reducing Union Run Tee URRT		35
Union Cross UUC		36

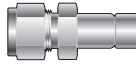
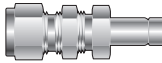

Stub Tube Connector

PART	ITEM	Page
Reducer UR		37~38
Bulkhead Reducer UBR		39
Male Adapter UMA		40

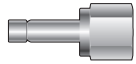
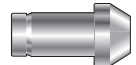
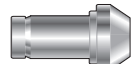

INDEX

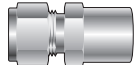
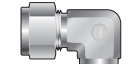
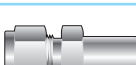
Female Adapter UFA		41
Port Connector UPC		42
Reducing Port Connector URPC		42

Tube to Welded Systems

PART	ITEM	Page
Male Pipe Weld Connector UPCW		43
Male Pipe Weld Elbow UPEW		44
Socket Weld Connector UPCSW		44
Socket Weld Elbow UPESW		44

Tube to AN(37° Flare) Tube

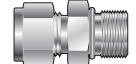

PART	ITEM	Page
An Union UUA		45
An Bulkhead Union UBUA		45
An Adapter UAA		45

Tube to SAE/O-Ring Seal

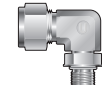
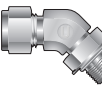
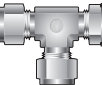
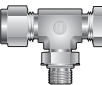
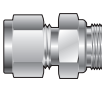
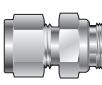
PART	ITEM	Page
SAE Male Connector UMCS		46

Positionable SAE Male Elbow UMES		46
Positionable SAE 45° Male Elbow UMVES		47
Positionable Male Run Tee UMRTS		47
Positionable Male Branch Tee UMBTS		47
O-Seal Straight Thread Connector UMOS		48
O-Seal Pipe Thread Connector UMOP		48

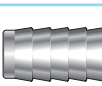
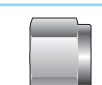
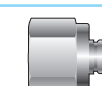
Components

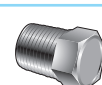
PART	ITEM	Page
Tube Cap UC		49
Tube Insert UI		50
Nut UN		51
Tube Plug UP		52
Front Ferrule UFF		53
Back Ferrule UBF		53
Vent Protector UVP		54

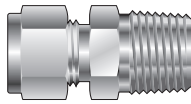

Male Connector
UMC

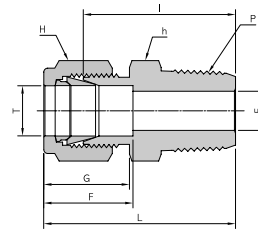

Connects Fractional Tube to Female NPT Thread

Part No.	Tube O.D. T		P (NPT)	E Min	h		H		F	G	l	L
	in	mm			in	mm	in	mm				
02UMC-02N	1/8	3.17	1/8	2.3	7/16	11.11	7/16	11.11	12.7	15.2	23.9	30.5
02UMC-04N	1/8	3.17	1/4	2.3	9/16	14.28	7/16	11.11	12.7	15.2	29.0	35.6
02UMC-06N	1/8	3.17	3/8	2.3	11/16	17.46	7/16	11.11	12.7	15.2	29.2	35.8
02UMC-08N	1/8	3.17	1/2	2.3	7/8	22.22	7/16	11.11	12.7	15.2	35.6	42.2
03UMC-02N	3/16	4.76	1/8	3.0	7/16	11.11	1/2	12.70	13.7	16.0	24.7	31.2
03UMC-04N	3/16	4.76	1/4	3.0	9/16	14.28	1/2	12.70	13.7	16.0	29.7	36.3
04UMC-02N	1/4	6.35	1/8	4.8	1/2	12.70	9/16	14.28	15.2	17.8	25.4	32.8
04UMC-04N	1/4	6.35	1/4	4.8	9/16	14.28	9/16	14.28	15.2	17.8	30.5	37.8
04UMC-06N	1/4	6.35	3/8	4.8	11/16	17.46	9/16	14.28	15.2	17.8	31.0	38.4
04UMC-08N	1/4	6.35	1/2	4.8	7/8	22.22	9/16	14.28	15.2	17.8	37.4	44.7
04UMC-12N	1/4	6.35	3/4	4.8	1-1/16	26.98	9/16	14.28	15.2	17.8	38.9	46.2
05UMC-02N	5/16	7.93	1/8	4.8	9/16	14.28	5/8	15.87	16.3	18.5	26.7	34.0
05UMC-04N	5/16	7.93	1/4	6.4	9/16	14.28	5/8	15.87	16.3	18.5	31.3	38.6
05UMC-06N	5/16	7.93	3/8	6.4	11/16	17.46	5/8	15.87	16.3	18.5	31.8	39.1
06UMC-02N	3/8	9.52	1/8	4.8	5/8	15.87	11/16	17.46	16.8	19.3	28.0	35.3
06UMC-04N	3/8	9.52	1/4	6.4	5/8	15.87	11/16	17.46	16.8	19.3	32.5	39.9
06UMC-06N	3/8	9.52	3/8	7.0	11/16	17.46	11/16	17.46	16.8	19.3	32.5	39.9
06UMC-08N	3/8	9.52	1/2	7.0	7/8	22.22	11/16	17.46	16.8	19.3	38.9	46.2
06UMC-12N	3/8	9.52	3/4	7.0	1-1/16	26.98	11/16	17.46	16.8	19.3	40.4	47.8
08UMC-02N	1/2	12.70	1/8	4.8	13/16	20.63	7/8	22.22	22.9	21.8	28.7	38.9
08UMC-04N	1/2	12.70	1/4	6.4	13/16	20.63	7/8	22.22	22.9	21.8	33.3	43.4
08UMC-06N	1/2	12.70	3/8	10.0	13/16	20.63	7/8	22.22	22.9	21.8	33.3	43.4
08UMC-08N	1/2	12.70	1/2	10.0	7/8	22.22	7/8	22.22	22.9	21.8	38.9	49.0
08UMC-12N	1/2	12.70	3/4	10.0	1-1/16	26.98	7/8	22.22	22.9	21.8	40.4	50.5
08UMC-16N	1/2	12.70	1	10.0	1-3/8	34.92	7/8	22.22	22.9	21.8	47.0	57.2
10UMC-06N	5/8	15.87	3/8	10.0	15/16	23.81	1	25.40	24.4	21.8	34.0	44.2
10UMC-08N	5/8	15.87	1/2	12.0	15/16	23.81	1	25.40	24.4	21.8	38.9	49.0
10UMC-12N	5/8	15.87	3/4	12.0	1-1/16	26.98	1	25.40	24.4	21.8	40.4	50.5
12UMC-08N	3/4	19.05	1/2	12.0	1-1/16	26.98	1-1/8	28.57	24.4	21.8	40.4	50.5
12UMC-12N	3/4	19.05	3/4	16.0	1-1/16	26.98	1-1/8	28.57	24.4	21.8	40.4	50.5
12UMC-16N	3/4	19.05	1	16.0	1-3/8	34.92	1-1/8	28.57	24.4	21.8	47.0	57.2
14UMC-12N	7/8	22.22	3/4	16.0	1-3/16	30.16	1-1/4	31.75	25.9	21.8	40.4	50.5
14UMC-16N	7/8	22.22	1	18.0	1-3/8	34.92	1-1/4	31.75	25.9	21.8	47.0	57.2
16UMC-08N	1	25.40	1/2	12.0	1-3/8	34.92	1-1/2	38.10	31.2	26.4	45.2	57.4
16UMC-12N	1	25.40	3/4	16.0	1-3/8	34.92	1-1/2	38.10	31.2	26.4	45.2	57.4
16UMC-16N	1	25.40	1	22.0	1-3/8	34.92	1-1/2	38.10	31.2	26.4	50.0	62.2

Female ISO Tapered Threads are available for all fractional UMC. Add "R" as a suffix instead of "N".
 Note : Dimensions are reference only, subject to change without prior notice. F, G and L are typical finger tight

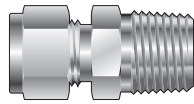

Male Connector
UMC

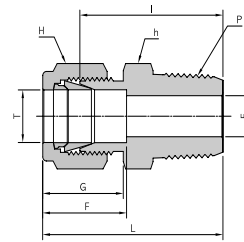

Connects Metric Tube to Female ISO Tapered Thread

Part No.	Tube O.D. T(mm)	P R(PT)	E Min	h	H	F	G	l	L
M03UMC-02R	3	1/8	2.3	11.11	11.11	12.9	15.3	23.9	29.7
M03UMC-04R	3	1/4	2.3	14.28	11.11	12.9	15.3	29.0	35.6
M04UMC-02R	4	1/8	2.3	11.11	12.70	13.7	16.1	24.6	31.2
M04UMC-04R	4	1/4	2.3	14.28	12.70	13.7	16.1	29.7	36.3
M06UMC-02R	6	1/8	4.8	12.70	14.28	15.3	17.7	25.4	32.8
M06UMC-04R	6	1/4	4.8	14.28	14.28	15.3	17.7	30.2	37.6
M06UMC-06R	6	3/8	4.8	17.46	14.28	15.3	17.7	31.0	38.4
M06UMC-08R	6	1/2	4.8	22.22	14.28	15.3	17.7	36.6	44.0
M08UMC-02R	8	1/8	4.8	14.28	15.87	16.2	18.6	26.7	34.2
M08UMC-04R	8	1/4	6.4	14.28	15.87	16.2	18.6	31.2	38.7
M08UMC-06R	8	3/8	6.4	17.46	15.87	16.2	18.6	31.8	39.2
M08UMC-08R	8	1/2	6.4	22.22	15.87	16.2	18.6	38.1	44.8
M10UMC-02R	10	1/8	4.8	17.46	19.05	17.2	19.5	28.7	36.3
M10UMC-04R	10	1/4	7.0	17.46	19.05	17.2	19.5	33.3	40.9
M10UMC-06R	10	3/8	8.0	17.46	19.05	17.2	19.5	33.3	40.9
M10UMC-08R	10	1/2	8.0	22.22	19.05	17.2	19.5	38.9	45.7
M12UMC-04R	12	1/4	7.0	20.63	22.22	22.8	22.0	33.3	43.4
M12UMC-06R	12	3/8	9.5	20.63	22.22	22.8	22.0	33.3	43.4
M12UMC-08R	12	1/2	9.5	22.22	22.22	22.8	22.0	38.1	48.2
M12UMC-12R	12	3/4	9.5	26.98	22.22	22.8	22.0	38.9	49.0
M14UMC-08R	14	1/2	11.1	23.81	23.81	24.4	22.0	38.9	49.0
M15UMC-08R	15	1/2	12.0	23.81	25.40	24.4	22.0	38.9	49.0
M16UMC-04R	16	1/4	7.0	23.81	25.40	24.4	22.0	34.0	44.1
M16UMC-06R	16	3/8	12.0	23.81	25.40	24.4	22.0	34.0	44.1
M16UMC-08R	16	1/2	12.0	23.81	25.40	24.4	22.0	38.9	49.0
M16UMC-12R	16	3/4	12.0	26.98	25.40	24.4	22.0	38.9	49.0
M18UMC-08R	18	1/2	12.0	26.98	30.16	24.4	22.0	38.9	50.5
M18UMC-12R	18	3/4	15.0	26.98	30.16	24.4	22.0	40.4	49.0
M20UMC-08R	20	1/2	12.0	30.16	31.75	26.0	22.0	42.2	52.3
M20UMC-12R	20	3/4	16.0	30.16	31.75	26.0	22.0	42.2	52.3
M22UMC-12R	22	3/4	16.0	30.16	31.75	26.0	22.0	42.2	52.3
M22UMC-16R	22	1	18.0	34.92	31.75	26.0	22.0	47.8	57.9
M25UMC-12R	25	3/4	16.0	34.92	38.10	31.3	26.5	45.2	57.5
M25UMC-16R	25	1	22.0	34.92	38.10	31.3	26.5	50.0	62.3

Male NPT Threads are available for all metric UMC. Add "N" as a suffix instead of "R".

Note : Dimensions are reference only, subject to change without prior notice. F,G and L are typical finger tight.

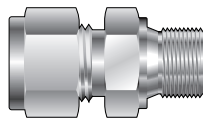

Male Connector
for Bonded Seal
UMC-G

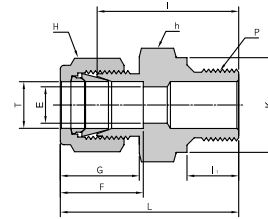

Connects Fractional Tube to Female ISO Parallel Thread

Part No.	Tube O.D. T		P G(PF)	E Min	h		H		F	G	l	l ₁	L	K
	in	mm			in	mm	in	mm						
02UMC-02G	1/8	3.17	1/8	2.3	9/16	14.28	7/16	11.11	12.7	15.2	23.4	7.1	30.0	13.8
02UMC-04G	1/8	3.17	1/4	2.3	3/4	19.05	7/16	11.11	12.7	15.2	28.7	11.2	35.3	18.0
02UMC-06G	1/8	3.17	3/8	2.3	7/8	22.22	7/16	11.11	12.7	15.2	29.7	11.2	36.2	21.8
04UMC-02G	1/4	6.35	1/8	4.8	9/16	14.28	9/16	14.28	15.2	17.8	24.9	7.1	32.3	13.8
04UMC-04G	1/4	6.35	1/4	4.8	3/4	19.05	9/16	14.28	15.2	17.8	30.2	11.2	37.6	18.0
04UMC-06G	1/4	6.35	3/8	4.8	7/8	22.22	9/16	14.28	15.2	17.8	31.5	11.2	38.9	21.8
04UMC-08G	1/4	6.35	1/2	4.8	1-1/16	26.98	9/16	14.28	15.2	17.8	37.3	14.2	44.7	25.9
06UMC-04G	3/8	9.52	1/4	4.8	3/4	19.05	11/16	17.46	16.8	19.3	31.8	11.2	39.1	18.0
06UMC-06G	3/8	9.52	3/8	7.0	7/8	22.22	11/16	17.46	16.8	19.3	33.0	11.2	40.4	21.8
06UMC-08G	3/8	9.52	1/2	7.0	1-1/16	26.98	11/16	17.46	16.8	19.3	38.9	14.2	46.2	25.9
08UMC-04G	1/2	12.70	1/4	6.0	13/16	20.63	7/8	22.22	22.9	21.8	32.5	11.2	42.6	18.0
08UMC-06G	1/2	12.70	3/8	8.0	7/8	22.22	7/8	22.22	22.9	21.8	33.0	11.2	43.2	21.8
08UMC-08G	1/2	12.70	1/2	10.0	1-1/16	26.98	7/8	22.22	22.9	21.8	38.8	14.2	49.0	25.9
12UMC-08G	3/4	19.05	1/2	12.0	1-1/16	26.98	1-1/8	28.57	24.4	21.8	38.8	14.2	49.0	25.9
12UMC-12G	3/4	19.05	3/4	16.0	1-5/16	33.33	1-1/8	28.57	24.4	21.8	42.6	15.7	53.8	32.0
16UMC-12G	1	25.40	3/4	16.0	1-3/8	34.92	1-1/2	38.10	31.2	26.4	45.2	15.7	57.5	32.0
16UMC-16G	1	25.40	1	22.0	1-5/8	41.27	1-1/2	38.10	31.2	26.4	47.8	18.3	59.9	39.0

Connects Metric Tube to Female ISO Parallel Thread

Part No.	Tube O.D. T(mm)	P G(PF)	E Min	h	H	F	G	l	l ₁	L	K
M03UMC-02G	3	1/8	2.3	14.28	11.11	12.9	15.3	23.4	7.1	30.0	13.8
M03UMC-04G	3	1/4	2.3	19.05	11.11	12.9	15.3	28.7	11.2	35.3	18.0
M04UMC-02G	4	1/8	2.3	14.05	12.70	13.7	16.1	24.1	7.1	30.7	13.8
M04UMC-04G	4	1/4	2.3	19.05	12.70	13.7	16.1	29.4	11.2	36.0	18.0
M06UMC-02G	6	1/8	4.0	14.05	14.28	15.3	17.7	24.9	7.1	32.3	13.8
M06UMC-04G	6	1/4	4.8	19.05	14.28	15.3	17.7	30.2	11.2	37.6	18.0
M06UMC-06G	6	3/8	4.8	22.22	14.28	15.3	17.7	31.5	11.2	38.9	21.8
M06UMC-08G	6	1/2	4.8	26.98	14.28	15.3	17.7	37.3	14.2	44.7	26.0
M08UMC-02G	8	1/8	4.0	15.87	15.87	16.2	18.6	25.7	7.1	33.2	13.8
M08UMC-04G	8	1/4	6.4	19.05	15.87	16.2	18.6	31.0	11.2	38.5	18.0
M08UMC-06G	8	3/8	6.4	22.22	15.87	16.2	18.6	32.3	11.2	39.8	21.8
M08UMC-08G	8	1/2	6.4	26.98	15.87	16.2	18.6	38.1	14.2	45.6	26.0
M10UMC-04G	10	1/8	6.4	19.05	19.05	17.2	19.5	31.8	11.2	39.4	18.0
M10UMC-06G	10	1/4	8.0	22.22	19.05	17.2	19.5	33.0	11.2	40.6	21.8
M10UMC-08G	10	3/8	8.0	26.98	19.05	17.2	19.5	38.9	14.2	46.5	26.0
M12UMC-04G	12	1/4	6.0	22.22	22.22	22.8	22.0	32.5	11.2	42.6	18.0
M12UMC-06G	12	3/8	8.0	22.22	22.22	22.8	22.0	33.0	11.2	43.1	21.8
M12UMC-08G	12	1/2	9.5	26.98	22.22	22.8	22.0	38.9	14.2	49.0	26.0
M12UMC-12G	12	3/4	9.5	31.75	22.22	22.8	22.0	42.7	15.7	52.8	32.0
M16UMC-06G	16	3/8	8.0	23.81	25.40	24.4	22.0	33.8	11.2	43.9	21.8
M16UMC-08G	16	1/2	12.0	26.98	25.40	24.4	22.0	38.9	14.2	49.0	26.0
M18UMC-08G	18	1/2	12.0	26.98	30.16	24.4	22.0	38.9	14.2	49.0	26.0
M18UMC-12G	18	3/4	16.0	34.92	30.16	24.4	22.0	42.7	15.7	52.8	32.0
M20UMC-08G	20	1/2	12.0	30.16	31.75	26.0	22.0	40.4	14.2	50.5	26.0
M20UMC-12G	20	3/4	16.0	34.92	31.75	26.0	22.0	42.7	15.7	52.8	32.0
M22UMC-12G	22	3/4	16.0	34.92	31.75	26.0	22.0	42.7	15.7	52.8	32.0
M22UMC-16G	22	1	18.0	41.27	31.75	26.0	22.0	45.2	18.3	55.3	39.0
M25UMC-12G	25	3/4	16.0	34.92	38.10	31.3	26.5	45.2	15.7	57.5	32.0
M25UMC-16G	25	1	20.0	41.27	38.10	31.3	26.5	47.8	18.3	60.1	39.0

Tube Fittings • UMC-M

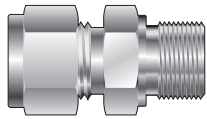

Male Connector
for Metal Gasket
UMC-M

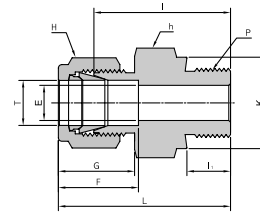

Connects Fractional Tube to Female ISO Parallel Thread

Part No.	Tube O.D.		P G(PF)	E Min	h		H		F	G	l	l ₁	L	K
	in	mm			in	mm	in	mm						
02UMC-02M	1/8	3.17	1/8	2.3	9/16	14.28	7/16	11.11	12.7	15.2	23.4	7.1	30.0	13.8
02UMC-04M	1/8	3.17	1/4	2.3	3/4	19.05	7/16	11.11	12.7	15.2	28.7	11.2	35.3	18.0
02UMC-06M	1/8	3.17	3/8	2.3	7/8	22.22	7/16	11.11	12.7	15.2	29.7	11.2	36.2	21.8
04UMC-02M	1/4	6.35	1/8	2.3	9/16	14.28	9/16	14.28	15.2	17.8	24.9	7.1	32.3	13.8
04UMC-04M	1/4	6.35	1/4	4.8	3/4	19.05	9/16	14.28	15.2	17.8	30.2	11.2	37.6	18.0
04UMC-06M	1/4	6.35	3/8	4.8	7/8	22.22	9/16	14.28	15.2	17.8	31.5	11.2	38.9	21.8
04UMC-08M	1/4	6.35	1/2	4.8	1-1/16	26.98	9/16	14.28	15.2	17.8	37.3	14.2	44.7	25.9
06UMC-04M	3/8	9.52	1/4	4.8	3/4	19.05	11/16	17.46	16.8	19.3	31.8	11.2	39.1	18.0
06UMC-06M	3/8	9.52	3/8	7.0	7/8	22.22	11/16	17.46	16.8	19.3	33.0	11.2	40.4	21.8
06UMC-08M	3/8	9.52	1/2	7.0	1-1/16	26.98	11/16	17.46	16.8	19.3	38.9	14.2	46.2	25.9
08UMC-04M	1/2	12.70	1/4	7.0	13/16	20.63	7/8	22.22	22.9	21.8	32.5	11.2	42.6	18.0
08UMC-06M	1/2	12.70	3/8	10.0	7/8	22.22	7/8	22.22	22.9	21.8	33.0	11.2	43.2	21.8
08UMC-08M	1/2	12.70	1/2	10.0	1-1/16	26.98	7/8	22.22	22.9	21.8	38.8	14.2	49.0	25.9
12UMC-08M	3/4	19.05	1/2	12.0	1-1/16	26.98	1-1/8	28.57	24.4	21.8	38.8	14.2	49.0	25.9
12UMC-12M	3/4	19.05	3/4	16.0	1-5/16	33.33	1-1/8	28.57	24.4	21.8	42.6	15.7	53.8	32.0
16UMC-12M	1	25.40	3/4	16.0	1-3/8	34.92	1-1/2	38.10	31.2	26.4	45.2	15.7	57.5	32.0
16UMC-16M	1	25.40	1	20.0	1-5/8	41.27	1-1/2	38.10	31.2	26.4	47.8	18.3	59.9	39.0

Connects Metric Tube to Female ISO Parallel Thread

Part No.	Tube O.D. T(mm)	P G(PF)	E Min	h	H	F	G	l	l ₁	L	K
M03UMC-02M	3	1/8	2.3	14.28	11.11	12.9	15.3	23.4	7.1	30.0	13.8
M03UMC-04M	3	1/4	2.3	19.05	11.11	12.9	15.3	28.7	11.2	35.3	18.0
M04UMC-02M	4	1/8	2.3	14.05	12.70	13.7	16.1	24.1	7.1	30.7	13.8
M04UMC-04M	4	1/4	2.3	19.05	12.70	13.7	16.1	29.4	11.2	36.0	18.0
M06UMC-02M	6	1/8	4.0	14.05	14.28	15.3	17.7	24.9	7.1	32.3	13.8
M06UMC-04M	6	1/4	4.8	19.05	14.28	15.3	17.7	30.2	11.2	37.6	18.0
M06UMC-06M	6	3/8	4.8	22.22	14.28	15.3	17.7	31.5	11.2	38.9	21.8
M06UMC-08M	6	1/2	4.8	26.98	14.28	15.3	17.7	37.3	14.2	44.7	26.0
M08UMC-02M	8	1/8	4.0	15.87	15.87	16.2	18.6	25.7	7.1	33.2	13.8
M08UMC-04M	8	1/4	6.4	19.05	15.87	16.2	18.6	31.0	11.2	38.5	13.8
M08UMC-06M	8	3/8	6.4	22.22	15.87	16.2	18.6	32.3	11.2	39.8	21.8
M08UMC-08M	8	1/2	6.4	26.98	15.87	16.2	18.6	38.1	14.2	45.6	26.0
M10UMC-04M	10	1/8	6.4	19.05	19.05	17.2	19.5	31.8	11.2	39.4	18.0
M10UMC-06M	10	1/4	8.0	22.22	19.05	17.2	19.5	33.0	11.2	40.6	21.8
M10UMC-08M	10	3/8	8.0	26.98	19.05	17.2	19.5	38.9	14.2	46.5	26.0
M12UMC-04M	12	1/4	6.0	22.22	22.22	22.8	22.0	32.5	11.2	42.6	18.0
M12UMC-06M	12	3/8	8.0	22.22	22.22	22.8	22.0	33.0	11.2	43.1	21.8
M12UMC-08M	12	1/2	9.5	26.98	22.22	22.8	22.0	38.9	14.2	49.0	26.0
M12UMC-12M	12	3/4	9.5	31.75	22.22	22.8	22.0	42.7	15.7	52.8	32.0
M16UMC-06M	16	3/8	8.0	23.81	25.40	24.4	22.0	33.8	11.2	43.9	21.8
M16UMC-08M	16	1/2	12.0	26.98	25.40	24.4	22.0	38.9	14.2	49.0	26.0
M18UMC-08M	18	1/2	12.0	26.98	30.16	24.4	22.0	38.9	14.2	49.0	26.0
M18UMC-12M	18	3/4	16.0	34.92	30.16	24.4	22.0	42.7	15.7	52.8	32.0
M20UMC-08M	20	1/2	12.0	30.16	31.75	26.0	22.0	40.4	14.2	50.5	26.0
M20UMC-12M	20	3/4	16.0	34.92	31.75	26.0	22.0	42.7	15.7	52.8	32.0
M22UMC-12M	22	3/4	16.0	34.92	31.75	26.0	22.0	42.7	15.7	52.8	32.0
M22UMC-16M	22	1	18.0	41.27	31.75	26.0	22.0	45.2	18.3	55.3	39.0
M25UMC-12M	25	3/4	16.0	34.92	38.10	31.3	26.5	45.2	15.7	57.5	32.0
M25UMC-16M	25	1	20.0	41.27	38.10	31.3	26.5	47.8	18.3	60.1	39.0

Note : Dimensions are reference only, subject to change without prior notice. F, G and L are typical finger tight.

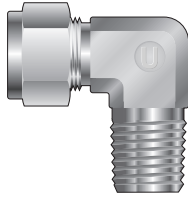

Male Elbow
UME

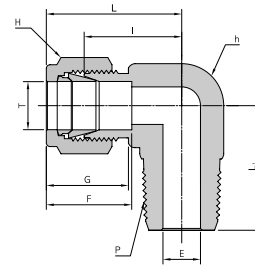

Connects Fractional Tube to Female NPT Thread

Part No.	Tube O.D. T		P (NPT)	E Min	h		H		F	G	l	L	L ₁
	in	mm			in	mm	in	mm					
02UME-02N	1/8	3.17	1/8	2.3	7/16	11.11	7/16	11.11	12.7	15.2	17.0	23.6	17.8
02UME-04N	1/8	3.17	1/4	2.3	1/2	12.70	7/16	11.11	12.7	15.2	18.0	24.6	23.4
03UME-02N	3/16	4.76	1/8	3.0	1/2	12.70	1/2	12.70	13.7	16.0	18.8	25.4	18.8
03UME-04N	3/16	4.76	1/4	3.0	1/2	12.70	1/2	12.70	13.7	16.0	18.8	25.4	23.4
04UME-02N	1/4	6.35	1/8	4.8	1/2	12.70	9/16	14.28	15.2	17.8	19.6	26.9	18.8
04UME-04N	1/4	6.35	1/4	4.8	1/2	12.70	9/16	14.28	15.2	17.8	19.6	26.9	23.4
04UME-06N	1/4	6.35	3/8	4.8	11/16	17.46	9/16	14.28	15.2	17.8	22.4	29.7	26.2
04UME-08N	1/4	6.35	1/2	4.8	13/16	20.63	9/16	14.28	15.2	17.8	24.4	31.8	33.0
05UME-02N	5/16	7.94	1/8	4.8	9/16	14.28	5/8	15.87	16.3	18.5	21.3	28.7	19.8
05UME-04N	5/16	7.94	1/4	6.3	9/16	14.28	5/8	15.87	16.3	18.5	21.3	28.7	24.4
05UME-06N	5/16	7.94	3/8	6.3	11/16	17.46	5/8	15.87	16.3	18.5	23.1	30.5	26.2
06UME-02N	3/8	9.52	1/8	4.8	5/8	15.87	11/16	17.46	16.8	19.3	23.1	30.5	20.8
06UME-04N	3/8	9.52	1/4	7.0	5/8	15.87	11/16	17.46	16.8	19.3	23.1	30.5	25.4
06UME-06N	3/8	9.52	3/8	7.0	11/16	17.46	11/16	17.46	16.8	19.3	23.9	31.2	26.2
06UME-08N	3/8	9.52	1/2	7.0	13/16	20.63	11/16	17.46	16.8	19.3	25.9	33.5	33.0
06UME-12N	3/8	9.52	3/4	7.0	1-1/16	26.98	11/16	17.46	16.8	19.3	29.7	37.1	36.8
08UME-04N	1/2	12.70	1/4	7.0	13/16	20.63	7/8	22.22	22.9	21.8	25.9	36.1	28.2
08UME-06N	1/2	12.70	3/8	10.0	13/16	20.63	7/8	22.22	22.9	21.8	25.9	36.1	28.2
08UME-08N	1/2	12.70	1/2	10.0	13/16	20.63	7/8	22.22	22.9	21.8	25.9	36.1	33.0
08UME-12N	1/2	12.70	3/4	10.0	1-1/16	26.98	7/8	22.22	22.9	21.8	29.7	39.9	36.8
10UME-06N	5/8	15.87	3/8	10.0	15/16	23.81	1	25.40	24.4	21.8	27.9	38.1	30.2
10UME-08N	5/8	15.87	1/2	12.0	15/16	23.81	1	25.40	24.4	21.8	27.9	38.1	35.1
10UME-12N	5/8	15.87	3/4	12.0	1-1/16	26.98	1	25.40	24.4	21.8	29.7	39.9	36.8
12UME-08N	3/4	19.05	1/2	12.0	1-1/16	26.98	1-1/8	28.57	24.4	21.8	29.7	39.9	36.8
12UME-12N	3/4	19.05	3/4	16.0	1-1/16	26.98	1-1/8	28.57	24.4	21.8	29.7	39.9	36.8
14UME-12N	7/8	22.22	3/4	16.0	1-1/4	31.75	1-1/4	31.75	25.9	21.8	34.5	44.7	41.7
16UME-12N	1	25.40	3/4	16.0	1-3/8	34.92	1-1/2	38.10	31.2	26.4	36.8	49.0	41.7
16UME-16N	1	25.40	1	22.0	1-3/8	34.92	1-1/2	38.10	31.2	26.4	36.8	49.0	46.5

Male ISO Tapered Threads are available for all fractional UME. Add "R" as a suffix instead of "N".

Note : Dimensions are reference only, subject to change without prior notice. F, G and L are typical finger tight.

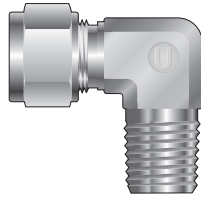

Male Elbow
UME

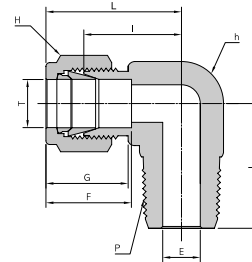

Connects Metric Tube to Female ISO Tapered Thread

Part No.	Tube O.D. T(mm)	P (PT)	E Min	h	H	F	G	I	L	L ₁
M03UME-02R	3	1/8	2.3	11.11	11.11	12.9	15.3	17.0	23.6	17.8
M03UME-04R	3	1/4	2.3	12.70	11.11	12.9	15.3	18.0	24.6	23.4
M04UME-02R	4	1/8	2.3	11.11	12.70	13.7	16.1	18.8	25.4	18.8
M04UME-04R	4	1/4	2.3	12.70	12.70	13.7	16.1	18.8	25.4	23.4
M06UME-02R	6	1/8	4.8	12.70	14.28	15.3	17.7	19.6	27.0	18.8
M06UME-04R	6	1/4	4.8	12.70	14.28	15.3	17.7	19.6	27.0	23.4
M06UME-06R	6	3/8	4.8	17.46	14.28	15.3	17.7	22.4	29.8	26.2
M06UME-08R	6	1/2	4.8	20.63	14.28	15.3	17.7	24.4	31.8	33.0
M08UME-02R	8	1/8	4.8	14.30	15.87	16.2	18.6	21.3	28.8	19.8
M08UME-04R	8	1/4	6.4	14.30	15.87	16.2	18.6	21.3	28.8	24.4
M08UME-06R	8	3/8	6.4	17.46	15.87	16.2	18.6	23.9	31.4	28.5
M08UME-08R	8	1/2	6.4	20.63	15.87	16.2	18.6	25.1	32.6	33.0
M10UME-02R	10	1/8	4.8	17.46	19.05	17.2	19.5	23.9	31.5	23.6
M10UME-04R	10	1/4	6.4	17.46	19.05	17.2	19.5	23.9	31.5	28.2
M10UME-06R	10	3/8	8.0	17.46	19.05	17.2	19.5	23.9	31.5	28.2
M10UME-08R	10	1/2	8.0	20.63	19.05	17.2	19.5	25.9	33.5	33.0
M12UME-04R	12	1/4	4.8	20.63	22.22	22.8	22.0	25.9	36.0	28.2
M12UME-06R	12	3/8	6.4	20.63	22.22	22.8	22.0	25.9	36.0	28.2
M12UME-08R	12	1/2	9.5	20.63	22.22	22.8	22.0	25.9	36.0	33.0
M12UME-12R	12	3/4	9.5	26.98	22.22	22.8	22.0	29.7	39.8	36.8
M14UME-08R	14	1/2	10.0	23.81	23.81	24.4	22.0	27.9	38.0	35.1
M15UME-08R	15	1/2	12.0	23.81	25.40	24.4	22.0	27.9	38.0	35.1
M16UME-06R	16	3/8	10.0	23.81	25.40	24.4	22.0	27.9	38.0	30.2
M16UME-08R	16	1/2	12.0	23.81	25.40	24.4	22.0	27.9	38.0	35.1
M16UME-12R	16	3/4	12.0	26.98	25.40	24.4	22.0	29.7	39.8	36.8
M18UME-08R	18	1/2	12.0	26.98	30.16	24.4	22.0	29.7	39.8	35.1
M18UME-12R	18	3/4	15.0	26.98	30.16	24.4	22.0	29.7	39.8	36.8
M20UME-08R	20	1/2	12.0	34.92	31.75	26.0	22.0	34.5	44.6	41.7
M20UME-12R	20	3/4	16.0	34.92	31.75	26.0	22.0	34.5	44.6	41.7
M22UME-12R	22	3/4	16.0	34.92	31.75	26.0	22.0	34.5	44.6	41.7
M22UME-16R	22	1	18.0	34.92	31.75	26.0	22.0	34.5	44.6	46.5
M25UME-12R	25	3/4	16.0	34.92	38.10	31.3	26.5	36.8	49.1	41.7
M25UME-16R	25	1	22.0	34.92	38.10	31.3	26.5	36.8	49.1	46.5

Male NPT Threads are available for all metric UME. Add "N" as a suffix instead of "R".

Note : Dimensions are reference only, subject to change without prior notice. F,G and L are typical finger tight.

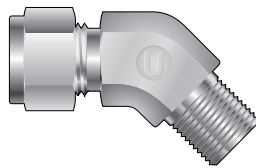

45° Male Elbow
UMVE

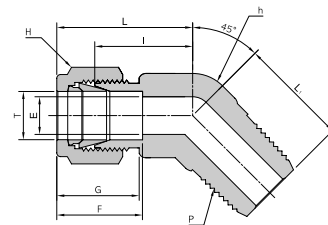

Connects Fractional Tube to Female NPT Thread

Part No.	Tube O.D. T		P (NPT)	E Min	h		H		F	G	l	L	L ₁
	in	mm			in	mm	in	mm					
04UMVE-02N	1/4	6.35	1/8	4.8	1/2	12.70	9/16	14.28	15.2	17.8	17.3	24.6	16.5
04UMVE-04N	1/4	6.35	1/4	4.8	1/2	12.70	9/16	14.28	15.2	17.8	17.3	24.6	21.0
06UMVE-02N	3/8	9.52	1/8	4.8	5/8	15.87	11/16	17.46	16.8	19.3	20.6	27.9	18.3
06UMVE-04N	3/8	9.52	1/4	7.0	5/8	15.87	11/16	17.46	16.8	19.3	20.6	27.9	22.9
06UMVE-06N	3/8	9.52	3/8	7.0	13/16	20.63	11/16	17.46	16.8	19.3	21.8	29.2	24.1
08UMVE-06N	1/2	12.70	3/8	10.0	13/16	20.63	7/8	22.22	22.9	21.8	21.8	32.0	24.1
08UMVE-08N	1/2	12.70	1/2	10.0	13/16	20.63	7/8	22.22	22.9	21.8	21.8	32.0	28.9
12UMVE-12N	3/4	19.05	3/4	16.0	1-1/8	28.57	1-1/8	28.57	24.4	21.8	23.9	34.0	31.0
16UMVE-16N	1	25.40	1	22.0	1-3/8	34.92	1-1/2	38.10	31.2	26.4	28.2	40.4	37.8

Male ISO Tapered Threads are available for all fractional UMVE. Add "R" as a suffix instead of "N".

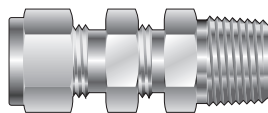

Bulkhead Male Connector
UBMC

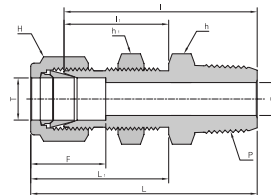

Connects Fractional Tube to Female NPT Thread

Part No.	Tube O.D. T		P (NPT)	E Min	h		h1		H		F	l	l ₁	L	L ₁	Panel Hole Drill Size	Max Panel Thickness
	in	mm			in	mm	in	mm	in	mm							
02UBMC-02N	1/8	3.17	1/8	2.3	1/2	12.70	1/2	12.70	7/16	11.11	12.7	39.8	24.6	46.5	31.2	8.3	12.7
04UBMC-02N	1/4	6.35	1/8	4.8	5/8	15.87	5/8	15.87	9/16	14.28	15.2	42.2	26.2	49.5	33.5	11.5	10.2
04UBMC-04N	1/4	6.35	1/4	4.8	5/8	15.87	5/8	15.87	9/16	14.28	15.2	46.0	26.2	53.3	33.5	11.5	10.2
06UBMC-04N	3/8	9.52	1/4	7.0	3/4	19.05	3/4	19.05	11/16	17.46	16.8	50.0	29.5	57.4	36.8	14.7	11.2
08UBMC-06N	1/2	12.70	3/8	10.0	15/16	23.81	15/16	23.81	7/8	22.22	22.9	53.0	31.8	63.2	41.9	19.5	12.7
08UBMC-08N	1/2	12.70	1/2	10.0	15/16	23.81	15/16	23.81	7/8	22.22	22.9	58.7	31.8	68.8	41.9	19.5	12.7

Connects Metric Tube to Female ISO Tapered Thread

Part No.	Tube O.D. T(mm)	P R(PT)	E Min	h	h1	H	F	l	l ₁	L	L ₁	Panel Hole Drill Size	Max Panel Thickness
M06UBMC-02R	6	1/8	4.8	15.87	15.87	14.28	15.3	42.2	26.2	49.5	33.6	11.5	10.2
M06UBMC-04R	6	1/4	4.8	15.87	15.87	14.28	15.3	46.0	26.2	53.3	33.6	11.5	10.2
M08UBMC-04R	8	1/4	6.4	17.46	17.46	15.87	16.2	49.0	28.6	57.4	36.1	13.1	11.2
M12UBMC-06R	12	3/8	9.5	23.81	23.81	22.22	22.8	53.1	31.8	63.2	41.9	19.5	12.7
M12UBMC-08R	12	1/2	9.5	23.81	23.81	22.22	22.8	58.7	31.8	68.8	41.9	19.5	12.7

ThermoCouple Male Connector
UTMC

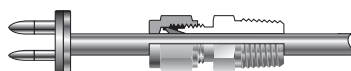

Thermocouples or dip tubes are easily handled by Uni-Lok Thermal Couple Male Connector. The root diameter of the pipe thread end of Male Connector makes it impractical to bore through all male connector. Suffix "T" Male Connector's identifier.

Note : Male Connector whose the tube fitting end is larger than pipe thread end are not available at UTMC. 06UMC-02R or N, M08UMC-02R or N

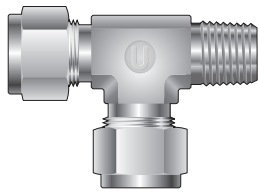

Male Run Tee
UMRT

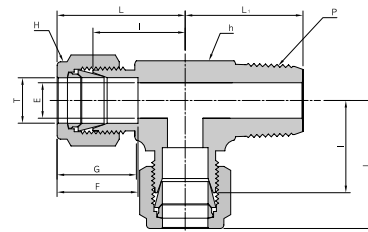

Connects Fractional Tube to Female NPT Thread

Part No.	Tube O.D. T		P (NPT)	E Min	h		H		F	G	I	L	L ₁
	in	mm			in	mm	in	mm					
02UMRT-02N	1/8	3.17	1/8	2.3	7/16	11.11	7/16	11.11	12.7	15.2	17.0	23.6	17.8
02UMRT-04N	1/8	3.17	1/4	2.3	1/2	12.70	7/16	11.11	12.7	15.2	18.0	24.6	23.4
03UMRT-02N	3/16	4.76	1/8	3.0	7/16	11.11	1/2	12.70	13.7	16.0	17.8	24.4	17.8
04UMRT-02N	1/4	6.35	1/8	4.8	1/2	12.70	9/16	14.28	15.2	17.8	19.6	26.9	18.8
04UMRT-04N	1/4	6.35	1/4	4.8	1/2	12.70	9/16	14.28	15.2	17.8	19.6	26.9	23.4
05UMRT-02N	5/16	7.94	1/8	4.8	9/16	14.28	5/8	15.87	16.3	18.5	22.6	29.7	20.8
06UMRT-04N	3/8	9.52	1/4	6.4	5/8	15.87	11/16	17.46	16.8	19.3	23.1	30.5	25.4
06UMRT-06N	3/8	9.52	3/8	7.0	11/16	17.46	11/16	17.46	16.8	19.3	25.9	33.3	28.2
08UMRT-06N	1/2	12.70	3/8	10.0	13/16	20.63	7/8	22.22	22.9	21.8	25.9	36.1	28.2
08UMRT-08N	1/2	12.70	1/2	10.0	13/16	20.63	7/8	22.22	22.9	21.8	25.9	36.1	33.0
10UMRT-08N	5/8	15.87	1/2	12.0	15/16	23.81	1	25.40	24.4	21.8	27.9	38.1	35.1
12UMRT-12N	3/4	19.05	3/4	16.0	1-1/16	26.98	1-1/8	28.57	24.4	21.8	28.2	38.4	35.3

Male ISO Tapered Threads are available for all fractional UMRT. Add "R" as a suffix instead of "N".

Connects Metric Tube to Female ISO Tapered Thread

Part No.	Tube O.D. T(mm)	P (PT)	E Min	h	H	F	G	I	L	L ₁
M03UMRT-02R	3	1/8	2.3	11.11	11.11	12.9	15.3	17.0	23.6	17.8
M03UMRT-04R	3	1/4	2.3	12.70	11.11	12.9	15.3	18.0	24.6	23.4
M04UMRT-02R	4	1/8	2.3	11.11	12.70	13.7	16.1	18.8	25.4	18.8
M06UMRT-02R	6	1/8	4.8	12.70	14.28	15.3	17.7	19.6	27.0	18.8
M06UMRT-04R	6	1/4	4.8	12.70	14.28	15.3	17.7	19.6	27.0	23.4
M08UMRT-02R	8	1/8	4.8	14.28	15.87	16.2	18.6	21.3	28.8	19.8
M08UMRT-04R	8	1/4	6.4	14.28	15.87	16.2	18.6	21.3	28.8	24.4
M10UMRT-04R	10	1/4	7.0	17.46	19.05	17.2	19.5	23.9	31.5	28.2
M10UMRT-06R	10	3/8	8.0	17.46	19.05	17.2	19.5	23.9	31.5	28.2
M12UMRT-04R	12	1/4	7.0	20.63	22.22	22.8	22.0	25.9	36.0	28.2
M12UMRT-06R	12	3/8	9.5	20.63	22.22	22.8	22.0	25.9	36.0	28.2
M12UMRT-08R	12	1/2	9.5	20.63	22.22	22.8	22.0	25.9	36.0	33.0
M16UMRT-06R	16	3/8	10.0	25.40	25.40	24.4	22.0	27.9	38.0	30.2
M16UMRT-08R	16	1/2	12.0	25.40	25.40	24.4	22.0	27.9	38.0	35.1
M20UMRT-12R	20	3/4	16.0	31.75	31.75	26.0	22.0	34.5	44.6	41.7

Male NPT Threads are available for all metric UMRT. Add "N" as a suffix instead of "R".

Note : Dimensions are reference only, subject to change without prior notice. F,G and L are typical finger tight.

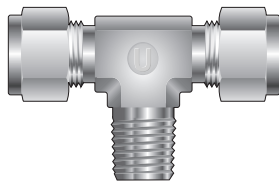

Male Branch Tee
UMBT

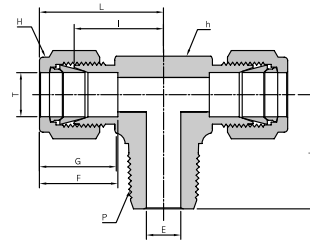

Connects Fractional Tube to Female NPT Thread

Part No.	Tube O.D. T		P (NPT)	E Min	h		H		F	G	l	L	L ₁
	in	mm			in	mm	in	mm					
02UMBT-02N	1/8	3.17	1/8	2.3	7/16	11.11	7/16	11.11	12.7	15.2	17.0	23.6	17.8
02UMBT-04N	1/8	3.17	1/4	2.3	1/2	12.70	7/16	11.11	12.7	15.2	18.0	24.6	23.4
03UMBT-02N	3/16	4.76	1/8	3.0	7/16	11.11	1/2	12.70	13.7	16.0	17.8	24.4	17.8
04UMBT-02N	1/4	6.35	1/8	4.8	1/2	12.70	9/16	14.28	15.2	17.8	19.6	26.9	18.8
04UMBT-04N	1/4	6.35	1/4	4.8	1/2	12.70	9/16	14.28	15.2	17.8	19.6	26.9	23.4
05UMBT-02N	5/16	7.93	1/8	4.8	9/16	14.28	5/8	15.87	16.3	18.5	22.4	29.7	20.8
06UMBT-04N	3/8	9.52	1/4	7.0	5/8	15.87	11/16	17.46	16.8	19.3	23.1	30.5	25.4
06UMBT-06N	3/8	9.52	3/8	7.0	11/16	17.46	11/16	17.46	16.8	19.3	25.9	33.3	28.2
08UMBT-06N	1/2	12.70	3/8	10.0	13/16	20.63	7/8	22.22	22.9	21.8	25.9	36.1	28.2
08UMBT-08N	1/2	12.70	1/2	10.0	13/16	20.63	7/8	22.22	22.9	21.8	25.9	36.1	33.0
10UMBT-08N	5/8	15.87	1/2	12.0	15/16	23.81	1	25.40	24.4	21.8	27.9	38.1	35.1
12UMBT-12N	3/4	19.05	3/4	16.0	1-1/16	26.98	1-1/8	28.57	24.4	21.8	28.2	38.4	35.3

Male ISO Tapered Threads are available for all fractional UMBT. Add "R" as a suffix instead of "N".

Connects Metric Tube to Female ISO Tapered Thread

Part No.	Tube O.D. T(mm)	P (PT)	E Min	h	H	F	G	l	L	L ₁
M03UMBT-02R	3	1/8	2.3	11.11	11.11	12.9	15.3	17.0	23.6	17.8
M03UMBT-04R	3	1/4	2.3	12.70	11.11	12.9	15.3	18.0	24.6	23.4
M04UMBT-02R	4	1/8	2.3	11.11	12.70	13.7	16.1	18.8	25.4	18.8
M06UMBT-02R	6	1/8	4.8	12.70	14.28	15.3	17.7	19.6	27.0	18.8
M06UMBT-04R	6	1/4	4.8	12.70	14.28	15.3	17.7	19.6	27.0	23.4
M08UMBT-02R	8	1/8	4.8	14.28	15.87	16.2	18.6	21.3	28.8	19.8
M08UMBT-04R	8	1/4	6.4	14.28	15.87	16.2	18.6	21.3	28.8	24.4
M10UMBT-04R	10	1/4	6.4	17.46	19.05	17.2	19.5	23.9	31.5	28.2
M10UMBT-06R	10	3/8	8.0	17.46	19.05	17.2	19.5	23.9	31.5	28.2
M12UMBT-04R	12	1/4	6.4	20.63	22.22	22.8	22.0	25.9	36.0	28.2
M12UMBT-06R	12	3/8	9.5	20.63	22.22	22.8	22.0	25.9	36.0	28.2
M12UMBT-08R	12	1/2	9.5	20.63	22.22	22.8	22.0	25.9	36.0	33.0
M16UMBT-06R	16	3/8	10.0	25.40	25.40	24.4	22.0	27.9	38.0	30.2
M16UMBT-08R	16	1/2	12.0	25.40	25.40	24.4	22.0	27.9	38.0	35.1
M20UMBT-12R	20	3/4	16.0	31.75	31.75	26.0	22.0	34.5	44.6	41.7

Male NPT Threads are available for all metric UMBT. Add "N" as a suffix instead of "R".

Note : Dimensions are reference only, subject to change without prior notice. F, G and L are typical finger tight.

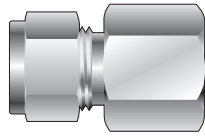

Female Connector
UFC

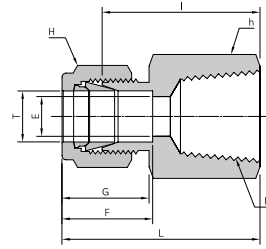

Connects Fractional Tube to Male NPT Thread

Part No.	Tube O.D. T		P (NPT)	E Min	h		H		F	G	l	L
	in	mm			in	mm	in	mm				
02UFC-02N	1/8	3.17	1/8	2.3	9/16	14.28	7/16	11.11	12.7	15.2	22.1	28.7
02UFC-04N	1/8	3.17	1/4	2.3	3/4	19.05	7/16	11.11	12.7	15.2	26.9	33.5
03UFC-02N	3/16	4.76	1/8	3.0	9/16	14.28	1/2	12.70	13.7	16.0	23.1	29.7
04UFC-02N	1/4	6.35	1/8	4.8	9/16	14.28	9/16	14.28	15.2	17.8	23.8	31.2
04UFC-04N	1/4	6.35	1/4	4.8	3/4	19.05	9/16	14.28	15.2	17.8	28.4	35.8
04UFC-06N	1/4	6.35	3/8	4.8	7/8	22.22	9/16	14.28	15.2	17.8	30.2	37.6
04UFC-08N	1/4	6.35	1/2	4.8	1-1/16	26.98	9/16	14.28	15.2	17.8	35.1	42.4
05UFC-02N	5/16	7.93	1/8	6.4	9/16	14.28	5/8	15.87	16.3	18.5	24.6	32.0
05UFC-04N	5/16	7.93	1/4	6.4	3/4	19.05	5/8	15.87	16.3	18.5	29.5	36.8
06UFC-02N	3/8	9.52	1/8	7.0	5/8	15.87	11/16	17.46	16.8	19.3	25.4	32.8
06UFC-04N	3/8	9.52	1/4	7.0	3/4	19.05	11/16	17.46	16.8	19.3	30.2	37.6
06UFC-06N	3/8	9.52	3/8	7.0	7/8	22.22	11/16	17.46	16.8	19.3	31.8	39.1
06UFC-08N	3/8	9.52	1/2	7.0	1-1/16	26.98	11/16	17.46	16.8	19.3	36.6	43.9
06UFC-12N	3/8	9.52	3/4	7.0	1-5/16	33.33	11/16	17.46	16.8	19.3	40.4	47.8
08UFC-04N	1/2	12.70	1/4	10.0	13/16	20.63	7/8	22.22	22.9	21.8	30.2	40.4
08UFC-06N	1/2	12.70	3/8	10.0	7/8	22.22	7/8	22.22	22.9	21.8	31.8	41.9
08UFC-08N	1/2	12.70	1/2	10.0	1-1/16	26.98	7/8	22.22	22.9	21.8	36.6	46.7
08UFC-12N	1/2	12.70	3/4	10.0	1-5/16	33.33	7/8	22.22	22.9	21.8	38.1	48.3
10UFC-06N	5/8	15.87	3/8	12.0	15/16	23.81	1	25.40	24.4	21.8	31.8	41.9
10UFC-08N	5/8	15.87	1/2	12.0	1-1/16	26.98	1	25.40	24.4	21.8	36.6	46.7
12UFC-08N	3/4	19.05	1/2	16.0	1-1/16	26.98	1-1/8	28.57	24.4	21.8	36.6	46.7
12UFC-12N	3/4	19.05	3/4	16.0	1-5/16	33.33	1-1/8	28.57	24.4	21.8	38.1	48.3
14UFC-12N	7/8	22.22	3/4	18.0	1-5/16	33.33	1-1/4	31.75	25.9	21.8	39.6	49.8
16UFC-12N	1	25.40	3/4	22.0	1-3/8	34.92	1-1/2	38.10	31.2	26.4	41.1	53.3
16UFC-16N	1	25.40	1	22.0	1-5/8	41.27	1-1/2	38.10	31.2	26.4	50.0	62.2

Female ISO Tapered Threads are available for all fractional UFC. Add "R" as a suffix instead of "N".

Note : Dimensions are reference only, subject to change without prior notice. F,G and L are typical finger tight.

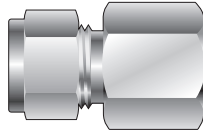

Female Connector
UFC

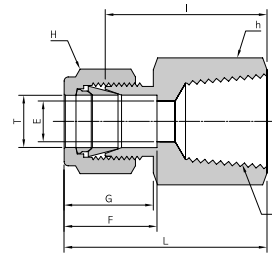

Connects Metric Tube to Male ISO Tapered Thread

Part No.	Tube O.D. T(mm)	P (PT)	E Min	h	H	F	G	l	L
M03UFC-02R	3	1/8	2.3	14.28	11.11	12.9	15.3	22.1	28.7
M03UFC-04R	3	1/4	2.3	19.05	11.11	12.9	15.3	26.9	33.5
M04UFC-02R	4	1/8	2.3	14.28	12.70	13.7	16.1	23.1	29.7
M06UFC-02R	6	1/8	4.8	14.28	14.28	15.3	17.7	23.9	31.3
M06UFC-04R	6	1/4	4.8	19.05	14.28	15.3	17.7	28.4	35.8
M06UFC-06R	6	3/8	4.8	22.22	14.28	15.3	17.7	29.5	36.9
M06UFC-08R	6	1/2	4.8	26.98	14.28	15.3	17.7	35.1	42.5
M08UFC-02R	8	1/8	6.4	14.28	15.87	16.2	18.6	24.6	32.1
M08UFC-04R	8	1/4	6.4	19.05	15.87	16.2	18.6	29.5	37.0
M08UFC-06R	8	3/8	6.4	22.22	15.87	16.2	18.6	30.2	37.0
M08UFC-08R	8	1/2	6.4	26.98	15.87	16.2	18.6	35.8	43.3
M10UFC-02R	10	1/8	8.0	17.46	19.05	17.2	19.5	25.4	33.0
M10UFC-04R	10	1/4	8.0	19.05	19.05	17.2	19.5	30.2	37.8
M10UFC-06R	10	3/8	8.0	22.22	19.05	17.2	19.5	31.0	38.6
M10UFC-08R	10	1/2	8.0	26.98	19.05	17.2	19.5	36.6	44.2
M12UFC-02R	12	1/8	8.0	22.22	22.22	22.8	22.0	28.4	38.5
M12UFC-04R	12	1/4	9.5	22.22	22.22	22.8	22.0	30.2	40.3
M12UFC-06R	12	3/8	9.5	22.22	22.22	22.8	22.0	31.0	41.1
M12UFC-08R	12	1/2	9.5	26.98	22.22	22.8	22.0	36.6	46.7
M12UFC-12R	12	3/4	9.5	33.33	22.22	22.8	22.0	38.9	49.0
M15UFC-08R	15	1/2	12.0	26.98	25.40	24.4	22.0	36.6	46.7
M16UFC-08R	16	1/2	12.0	26.98	25.40	24.4	22.0	36.8	46.9
M20UFC-08R	20	1/2	16.0	30.16	31.75	26.0	22.0	37.8	47.9
M20UFC-12R	20	3/4	16.0	34.92	31.75	26.0	22.0	39.6	49.7
M22UFC-12R	22	3/4	18.0	34.92	31.75	26.0	22.0	39.6	49.7
M22UFC-16R	22	1	18.0	41.27	31.75	26.0	22.0	47.8	57.9
M25UFC-12R	25	3/4	22.0	34.92	38.10	31.3	26.5	41.1	53.4
M25UFC-16R	25	1	22.0	41.27	38.10	31.3	26.5	50.0	62.3

Male NPT Threads are available for all metric UFC. Add "N" as a suffix instead of "R".

Note : Dimensions are reference only, subject to change without prior notice.

F,G and L are typical finger tight.

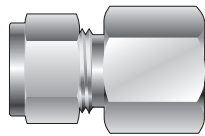

Gauge Connector
UGC

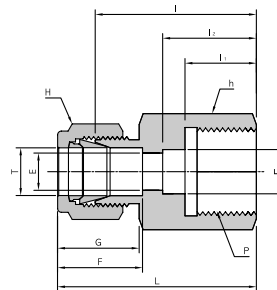

Connects Fractional Tube to ISO Parallel Thread (Gauge)

Part No.	Tube O.D. T		P (PF)	E Min	E ₁	h		H		F	G	I	I ₁	I ₂	L
	in	mm				in	mm	in	mm						
04UGC-02G	1/4	6.35	1/8	4.8	-	9/16	14.28	9/16	14.28	15.2	17.8	26.3	12.0	-	33.6
04UGC-04G	1/4	6.35	1/4	4.8	5.6	3/4	19.05	9/16	14.28	15.2	17.8	30.2	13.0	17.0	37.6
04UGC-06G	1/4	6.35	3/8	4.8	6.5	15/16	23.81	9/16	14.28	15.2	17.8	30.2	14.2	20.3	37.6
04UGC-08G	1/4	6.35	1/2	4.8	6.5	11/16	26.98	9/16	14.28	15.2	17.8	30.1	18.8	24.9	43.4
05UGC-04G	5/16	7.93	1/4	5.6	-	3/4	19.05	5/8	15.87	16.3	18.5	31.0	13.0	-	38.4
05UGC-08G	5/16	7.93	1/2	7.0	-	1-1/16	26.98	5/8	15.87	16.3	18.5	33.0	18.8	-	40.4
06UGC-04G	3/8	9.52	1/8	5.6	-	3/4	19.05	11/16	17.46	16.8	19.3	31.8	12.9	-	39.1
06UGC-06G	3/8	9.52	3/8	6.5	-	15/16	23.81	11/16	17.46	16.8	19.3	31.2	14.2	-	38.6
06UGC-08G	3/8	9.52	1/2	7.0	-	1-1/16	26.98	11/16	17.46	16.8	19.3	34.5	18.8	-	41.9
08UGC-04G	1/2	12.7	1/4	5.6	-	7/8	22.22	7/8	22.22	22.9	21.8	31.8	13.0	-	41.9
08UGC-06G	1/2	12.7	3/8	6.5	-	15/16	23.81	7/8	22.22	22.9	21.8	34.3	14.2	-	44.4
08UGC-08G	1/2	12.7	1/2	7.0	7.0	1-1/16	26.98	7/8	22.22	22.9	21.8	38.1	18.8	-	48.3

Connects Metric Tube to ISO Parallel Thread (Gauge)

Part No.	Tube O.D. T(mm)	P (PF)	E Min	E ₁	h	H	F	G	I	I ₁	I ₂	L
M03UGC-04G	3	1/4	2.3	5.6	19.05	12.70	12.9	15.3	28.7	13.0	17.0	35.3
M06UGC-04G	6	1/4	4.8	5.6	19.05	14.28	15.3	17.7	30.2	13.0	17.0	37.6
M06UGC-06G	6	3/8	4.8	6.5	23.81	14.28	15.3	17.7	30.2	14.0	20.0	37.6
M06UGC-08G	6	1/2	4.8	7.0	26.98	14.28	15.3	17.7	36.3	19.0	25.0	43.0
M08UGC-04G	8	1/4	5.6	-	19.05	15.87	16.2	18.6	31.0	13.0	-	38.5
M08UGC-08G	8	1/2	7.0	-	26.98	15.87	16.2	18.6	33.0	19.0	-	40.5
M10UGC-04G	10	1/4	5.6	-	19.05	19.05	17.2	19.5	31.8	13.0	-	39.4
M10UGC-06G	10	3/8	6.5	-	23.81	19.05	17.2	19.5	31.2	14.0	-	38.8
M10UGC-08G	10	1/2	7.0	-	26.98	19.05	17.2	19.5	33.8	19.0	-	41.4
M12UGC-04G	12	1/4	5.6	-	22.22	22.22	22.8	22.0	31.8	13.0	-	41.9
M12UGC-06G	12	3/8	6.5	-	23.81	22.22	22.8	22.0	34.3	14.0	-	44.4
M12UGC-08G	12	1/2	7.0	-	26.98	22.22	22.8	22.0	38.1	19.0	-	48.2
M20UGC-08G	20	1/2	7.0	-	30.16	31.75	26.0	22.0	44.2	19.0	-	54.3
M22UGC-08G	20	1/2	7.0	-	30.16	31.75	26.0	22.0	44.2	19.0	-	54.3

Note : Dimensions are reference only, subject to change without prior notice.

F,G and L are typical finger tight.

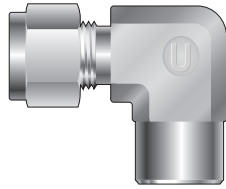

Female Elbow
UFE

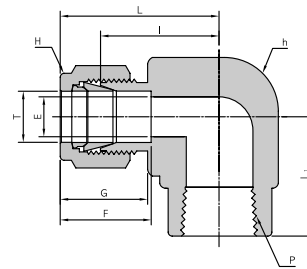

Connects Fractional Tube to Male NPT Thread

Part No.	Tube O.D. T		P (NPT)	E Min	h		H		F	G	l	L	L ₁
	in	mm			in	mm	in	mm					
02UFE-02N	1/8	3.17	1/8	2.3	1/2	12.70	7/16	11.11	12.7	15.2	18.0	24.6	19.1
02UFE-04N	1/8	3.17	1/4	2.3	11/16	17.46	7/16	11.11	12.7	15.2	20.8	27.4	22.4
03UFE-02N	3/16	4.76	1/8	3.0	1/2	12.70	1/2	12.70	13.7	16.0	18.8	25.4	19.1
04UFE-02N	1/4	6.35	1/8	4.8	1/2	12.70	9/16	14.28	15.2	17.8	19.6	26.9	19.1
04UFE-04N	1/4	6.35	1/4	4.8	11/16	17.46	9/16	14.28	15.2	17.8	22.4	29.7	22.4
04UFE-06N	1/4	6.35	3/8	4.8	13/16	20.63	9/16	14.28	15.2	17.8	24.4	31.8	22.4
04UFE-08N	1/4	6.35	1/2	4.8	1	25.40	9/16	14.28	15.2	17.8	27.2	24.5	28.4
05UFE-02N	5/16	7.93	1/8	6.4	9/16	14.28	5/8	15.87	16.2	18.5	21.3	28.7	19.1
05UFE-04N	5/16	7.93	1/4	6.4	11/16	17.46	5/8	15.87	16.2	18.5	23.1	30.5	22.4
06UFE-02N	3/8	9.52	1/8	7.0	5/8	15.87	11/16	17.46	16.8	19.3	23.1	30.5	19.1
06UFE-04N	3/8	9.52	1/4	7.0	11/16	17.46	11/16	17.46	16.8	19.3	23.8	31.2	22.4
06UFE-06N	3/8	9.52	3/8	7.0	13/16	20.63	11/16	17.46	16.8	19.3	25.9	33.3	22.4
06UFE-08N	3/8	9.52	1/2	7.0	1	25.40	11/16	17.46	16.8	19.3	28.7	36.1	28.4
08UFE-04N	1/2	12.70	1/4	10.0	13/16	20.63	7/8	22.22	22.9	21.8	25.9	36.1	22.4
08UFE-06N	1/2	12.70	3/8	10.0	13/16	20.63	7/8	22.22	22.9	21.8	25.9	36.1	22.4
08UFE-08N	1/2	12.70	1/2	10.0	1	25.40	7/8	22.22	22.9	21.8	28.7	38.9	28.4
10UFE-06N	5/8	15.87	3/8	12.0	15/16	23.80	1	25.40	24.4	21.8	27.9	38.1	22.4
10UFE-08N	5/8	15.87	1/2	12.0	1	25.40	1	25.40	24.4	21.8	29.7	39.9	28.4
12UFE-08N	3/4	19.05	1/2	16.0	1-1/16	26.98	1-1/8	28.57	24.4	21.8	29.7	39.9	28.4
12UFE-12N	3/4	19.05	3/4	16.0	1-1/4	31.75	1-1/8	28.57	24.4	21.8	34.5	44.7	31.8
14UFE-12N	7/8	22.22	3/4	18.0	1-1/4	31.75	1-1/4	31.75	25.9	21.8	34.5	44.7	31.8
16UFE-12N	1	25.40	3/4	22.0	1-3/8	34.92	1-1/2	38.10	31.2	26.4	36.8	49.0	31.8
16UFE-16N	1	25.40	1	22.0	1-11/16	42.86	1-1/2	38.10	31.2	26.4	38.1	50.3	38.1

Female ISO Tapered Threads are available for all fractional UFE. Add "R" as a suffix instead of "N".

Note : Dimensions are reference only, subject to change without prior notice. F, G and L are typical finger tight.

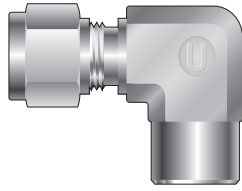

Female Elbow
UFE

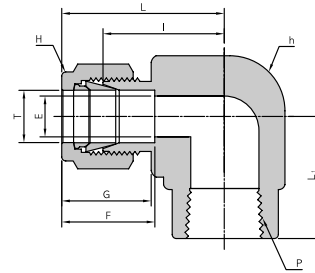

Connects Metric Tube to Male ISO Tapered Thread

Part No.	Tube O.D. T(mm)	P (PT)	E Min	h	H	F	G	l	L	L ₁
M06UFE-02R	6	1/8	4.8	12.70	14.28	15.3	17.7	19.6	26.9	19.1
M06UFE-04R	6	1/4	4.8	17.46	14.28	15.3	17.7	22.4	29.8	22.4
M06UFE-06R	6	3/8	4.8	20.63	14.28	15.3	17.7	24.4	31.7	22.4
M06UFE-08R	6	1/2	4.8	25.40	14.28	15.3	17.7	27.2	34.6	28.4
M08UFE-04R	8	1/4	6.4	17.46	15.87	16.2	18.6	23.1	30.6	22.4
M08UFE-08R	8	1/2	6.4	25.40	15.87	16.2	18.6	28.0	35.2	28.4
M10UFE-02R	10	1/8	8.0	17.46	19.05	17.2	19.5	25.9	33.5	19.1
M10UFE-04R	10	1/4	8.0	17.46	19.05	17.2	19.5	25.9	33.5	22.4
M10UFE-06R	10	3/8	8.0	20.63	19.05	17.2	19.5	25.9	33.5	22.4
M10UFE-08R	10	1/2	8.0	25.40	19.05	17.2	19.5	28.7	36.1	28.4
M12UFE-04R	12	1/4	9.5	20.63	22.22	22.8	22.0	25.9	36.1	22.4
M12UFE-06R	12	3/8	9.5	20.63	22.22	22.8	22.0	25.9	36.2	22.4
M12UFE-08R	12	1/2	9.5	25.40	22.22	22.8	22.0	28.7	38.8	28.4
M16UFE-08R	16	1/2	12.0	26.98	25.40	24.4	22.0	29.7	39.5	28.4

Male NPT Threads are available for all metric UFE. Add "N" as a suffix instead of "R".

Note : Dimensions are reference only, subject to change without prior notice. F,G and L are typical finger tight.

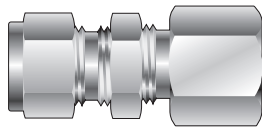

*Bulkhead
Female Connector*
UBFC

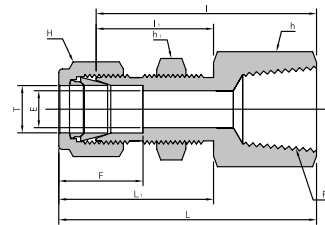

Connects Fractional Tube to Male NPT Thread

Part No.	Tube O.D. T		P (NPT)	E Min	h		h1		H		F	l	l ₁	L	L ₁	Panel Hole Drill Size	Max Panel Thickn ess
	in	mm			in	mm	in	mm	in	mm							
02UBFC-02N	1/8	3.17	1/8	2.3	9/16	14.28	1/2	12.70	7/16	11.11	12.7	38.1	24.6	44.7	31.2	8.3	12.7
04UBFC-02N	1/4	6.35	1/8	4.8	5/8	15.87	5/8	15.87	9/16	14.28	15.2	39.6	26.2	47.0	33.5	11.5	10.2
04UBFC-04N	1/4	6.35	1/4	4.8	3/4	19.05	5/8	15.87	9/16	14.28	15.2	44.5	26.2	51.8	33.5	11.5	10.2
06UBFC-04N	3/8	9.52	1/4	7.0	3/4	19.05	3/4	19.05	11/16	17.46	16.8	47.8	29.5	55.1	36.8	14.7	11.2
08UBFC-06N	1/2	12.70	3/8	10.0	15/16	23.81	15/16	23.81	7/8	22.22	22.9	51.6	31.8	61.7	41.9	19.4	12.7
08UBFC-08N	1/2	12.70	1/2	10.0	1-1/16	26.98	15/16	23.81	7/8	22.22	22.9	56.4	31.8	66.5	41.9	19.4	12.7
12UBFC-12N	3/4	19.05	3/4	16.0	1-1/4	31.75	1-3/16	30.16	1-1/8	25.87	24.4	63.6	38.3	73.5	47.2	25.8	16.8

Female ISO Tapered Threads are available for all fractional UBFC. Add "R" as a suffix instead of "N"

Connects Metric Tube to Male ISO Tapered Thread

Part No.	Tube O.D. T(mm)	P R(PT)	E Min	h	h1	H	F	l	l ₁	L	L ₁	Panel Hole Drill Size	Max Panel Thickn ess
M06UBFC-02R	6	1/8	4.8	15.87	15.87	14.28	15.3	39.6	27.7	46.9	33.6	11.5	10.2
M06UBFC-04R	6	1/4	4.8	19.05	15.87	14.28	15.3	44.4	26.2	51.8	33.6	11.5	10.2
M08UBFC-04R	8	1/4	6.4	19.05	17.46	15.87	16.2	46.7	28.4	53.9	35.6	13.1	11.2
M12UBFC-08R	12	1/2	9.5	26.98	23.81	22.22	22.8	56.4	31.8	66.5	41.9	19.5	12.7

Female NPT Threads are available for all metric UBFC. Add "N" as a suffix instead of "R".

Note : Dimensions are reference only, subject to change without prior notice. F,G and L are typical finger tight.

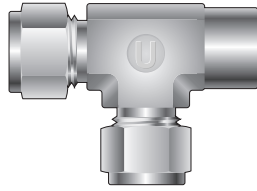

Female Run Tee
UFRT

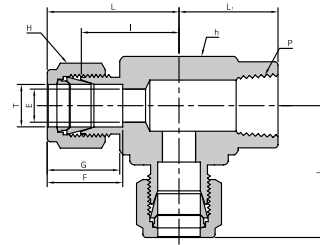

Connects Fractional Tube to Male NPT Thread

Part No.	Tube O.D. T		P (NPT)	E Min	h		H		F	G	I	L	L ₁
	in	mm			in	mm	in	mm					
02UFRT-02N	1/8	3.17	1/8	2.3	1/2	12.70	7/16	11.11	12.7	15.2	18.0	24.6	19.1
04UFRT-02N	1/4	6.35	1/8	4.8	1/2	12.70	9/16	14.28	15.2	17.8	19.6	26.9	19.1
04UFRT-04N	1/4	6.35	1/4	4.8	11/16	17.46	9/16	14.28	15.2	17.8	22.9	29.7	22.4
06UFRT-04N	3/8	9.52	1/4	7.0	11/16	17.46	11/16	17.46	16.8	19.3	23.9	31.2	22.4
08UFRT-06N	1/2	12.70	3/8	10.0	13/16	20.63	7/8	22.22	22.9	21.8	25.9	36.1	22.4
08UFRT-08N	1/2	12.70	1/2	10.0	1	25.40	7/8	22.22	22.9	21.8	29.7	39.9	28.4
12UFRT-12N	3/4	19.05	3/4	16.0	1-1/4	31.75	1-1/8	28.57	24.4	21.8	34.5	44.7	31.8
16UFRT-12N	1	25.40	3/4	22.0	1-3/8	34.92	1-1/2	38.10	31.2	26.4	36.8	49.0	31.8
16UFRT-16N	1	25.40	1	22.0	1-11/16	42.86	1-1/2	38.10	31.2	26.4	38.1	50.3	38.1

Female ISO Tapered Threads are available for all fractional UFRT. Add "R" as a suffix instead of "N".

Connects Metric Tube to Male ISO Tapered Thread

Part No.	Tube O.D. T(mm)	P (PT)	E Min	h	H	F	G	I	L	L ₁
M06UFRT-02R	6	1/8	4.8	12.70	14.3	15.3	17.7	19.6	26.9	19.1
M06UFRT-04R	6	1/4	4.8	17.46	14.3	15.3	17.7	22.4	29.7	22.4
M06UFRT-08R	6	1/2	4.8	25.40	14.3	15.3	17.7	27.2	34.5	28.4
M08UFRT-02R	8	1/8	6.4	15.87	15.87	16.2	18.6	22.4	29.9	19.1
M08UFRT-04R	8	1/4	6.4	17.46	15.87	16.2	18.6	23.1	30.6	22.4
M08UFRT-06R	8	3/8	6.4	20.63	15.87	16.2	18.6	25.2	32.4	22.4
M08UFRT-08R	8	1/2	6.4	25.40	15.87	16.2	18.6	28.0	35.2	28.4
M10UFRT-04R	10	1/4	8.0	20.63	19.05	17.2	19.5	25.9	33.5	22.4
M12UFRT-04R	12	1/4	9.5	20.63	22.22	22.8	22.0	25.9	36.1	22.4
M12UFRT-06R	12	3/8	9.5	20.63	22.22	22.8	22.0	25.9	36.1	22.4
M12UFRT-08R	12	1/2	9.5	26.98	22.22	22.8	22.0	29.7	39.9	28.4
M16UFRT-08R	16	1/2	12.0	25.40	25.40	24.4	22.0	29.7	39.9	28.4

Female NPT Threads are available for all metric UFRT. Add "N" as a suffix instead of "R".

Note : Dimensions are reference only, subject to change without prior notice. F,G and L are typical finger tight.

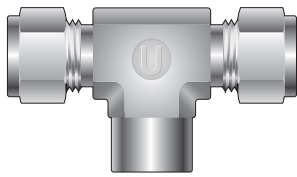

Female Branch Tee
UFBT

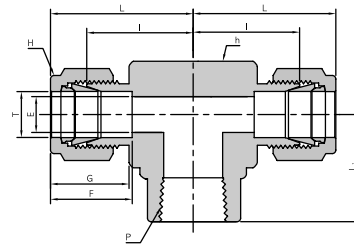

Connects Fractional Tube to Male NPT Thread

Part No.	Tube O.D. T		P (NPT)	E Min	h		H		F	G	l	L	L ₁
	in	mm			in	mm	in	mm					
02UFBT-02N	1/8	3.17	1/8	2.3	1/2	12.70	7/16	11.11	12.7	15.2	18.0	24.4	19.1
04UFBT-02N	1/4	6.35	1/8	4.8	1/2	12.70	9/16	14.28	15.2	17.8	19.6	26.9	19.1
04UFBT-04N	1/4	6.35	1/4	4.8	11/16	17.46	9/16	14.28	15.2	17.8	22.9	29.7	22.4
06UFBT-04N	3/8	9.52	1/4	7.0	11/16	17.46	11/16	17.46	16.8	19.3	23.9	31.2	22.4
08UFBT-04N	1/2	12.70	1/4	10.0	13/16	20.63	7/8	22.22	22.9	21.8	25.9	36.1	22.4
08UFBT-06N	1/2	12.70	3/8	10.0	13/16	20.63	7/8	22.22	22.9	21.8	25.9	36.1	22.4
08UFBT-08N	1/2	12.70	1/2	10.0	1	25.40	7/8	22.22	22.9	21.8	28.7	38.9	28.4
10UFBT-08N	5/8	15.87	1/2	12.0	1	25.40	1	25.40	24.4	21.8	28.7	38.9	28.4
12UFBT-12N	3/4	19.05	3/4	16.0	1-1/4	31.75	1-1/8	28.57	24.4	21.8	34.5	44.7	31.8
16UFBT-12N	1	25.40	3/4	22.0	1-3/8	34.92	1-1/2	38.10	31.2	26.4	36.8	49.0	31.8
16UFBT-16N	1	25.40	1	22.0	1-11/16	42.86	1-1/2	38.10	31.2	26.4	38.1	50.3	38.1

Female ISO Tapered Threads are available for all fractional UFBT. Add "R" as a suffix instead of "N".

Connects Metric Tube to Male ISO Tapered Thread

Part No.	Tube O.D. T(mm)	P (PT)	E Min	h	H	F	G	l	L	L ₁
M06UFBT-02R	6	1/8	4.8	12.70	14.3	15.3	17.7	19.6	26.9	19.1
M06UFBT-04R	6	1/4	4.8	17.46	14.3	15.3	17.7	22.4	29.7	22.4
M06UFBT-06R	6	3/8	4.8	20.63	14.3	15.3	17.7	24.4	31.7	22.4
M06UFBT-08R	6	1/2	4.8	25.40	14.3	15.3	17.7	27.2	34.5	28.4
M08UFBT-02R	8	1/8	6.4	15.87	15.87	16.2	18.6	22.4	29.9	19.1
M08UFBT-04R	8	1/4	6.4	17.46	15.87	16.2	18.6	23.1	30.6	22.4
M08UFBT-06R	8	3/8	6.4	20.63	15.87	16.2	18.6	25.2	32.4	22.4
M08UFBT-08R	8	1/2	6.4	25.40	15.87	16.2	18.6	28.0	35.2	28.4
M10UFBT-04R	10	1/4	8.0	20.63	19.05	17.2	19.5	25.9	33.5	22.4
M10UFBT-06R	10	3/8	8.0	20.63	19.05	17.2	19.5	25.9	33.3	22.4
M10UFBT-08R	10	1/2	8.0	25.40	19.05	17.2	19.5	26.2	33.6	22.4
M12UFBT-04R	12	1/4	9.5	20.63	22.22	22.8	22.0	25.9	36.1	22.4
M12UFBT-06R	12	3/8	9.5	20.63	22.22	22.8	22.0	25.9	36.1	22.4
M12UFBT-08R	12	1/2	9.5	25.40	22.22	22.8	22.0	29.7	38.9	28.4
M16UFBT-08R	16	1/2	12.0	25.40	25.40	24.4	22.0	29.7	38.9	28.7

Female NPT Threads are available for all metric UFBT. Add "N" as a suffix instead of "R".

Note : Dimensions are reference only, subject to change without prior notice. F,G and L are typical finger tight.

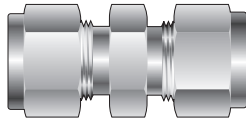

Union
UU

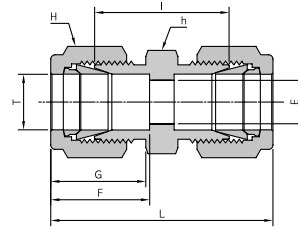

Connects Fractional Tube

Part No.	Tube O.D. T		E Min	h		H		F	G	l	L
	in	mm		in	mm	in	mm				
02UU	1/8	3.17	2.3	7/16	11.11	7/16	11.11	12.7	15.2	22.4	35.6
03UU	3/16	4.76	3.0	7/16	11.11	1/2	12.70	13.7	16.0	24.1	37.3
04UU	1/4	6.35	4.8	1/2	12.70	9/16	14.28	15.2	17.8	26.2	40.9
05UU	5/16	7.93	6.4	9/16	14.28	5/8	15.87	16.3	18.5	28.2	42.9
06UU	3/8	9.52	7.0	5/8	15.87	11/16	17.46	16.8	19.3	30.2	45.0
08UU	1/2	12.70	10.0	13/16	20.63	7/8	22.22	22.9	21.8	31.0	51.3
10UU	5/8	15.87	12.0	15/16	23.81	1	25.40	24.4	21.8	31.8	52.1
12UU	3/4	19.05	16.0	1-1/16	26.98	1-1/8	28.57	24.4	21.8	33.3	53.6
14UU	7/8	22.22	18.0	1-3/16	30.16	1-1/4	31.75	25.9	21.8	35.1	55.4
16UU	1	25.40	22.0	1-3/8	34.92	1-1/2	38.10	31.2	26.4	40.4	64.8

Connects Metric Tube

Part No.	Tube O.D. T(mm)	E Min	h	H	F	G	l	L
M03UU	3	2.3	11.11	11.11	12.9	15.3	22.1	35.3
M04UU	4	2.3	11.11	12.70	13.7	16.1	24.1	37.3
M06UU	6	4.8	12.70	14.28	15.3	17.7	26.2	41.0
M08UU	8	6.4	14.28	15.87	16.2	18.6	28.2	43.2
M10UU	10	8.0	17.46	19.05	17.2	19.5	31.0	46.2
M12UU	12	9.5	20.63	22.22	22.8	22.0	31.0	51.2
M15UU	15	12.0	23.81	25.40	24.4	22.0	31.8	52.0
M16UU	16	12.0	23.81	25.40	24.4	22.0	31.8	52.0
M18UU	18	15.0	26.98	30.16	24.4	22.0	33.3	53.5
M20UU	20	16.0	30.16	31.75	26.0	22.0	34.8	55.0
M22UU	22	18.0	30.16	31.75	26.0	22.0	34.8	55.0
M25UU	25	22.0	34.92	38.10	31.3	26.5	40.4	65.0

Note : Dimensions are reference only, subject to change without prior notice. F,G and L are typical finger tight.

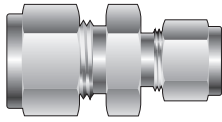

Reducing Union
URU

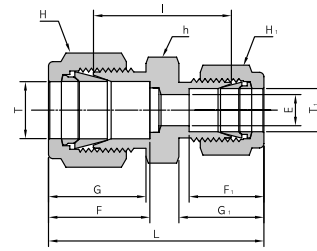

Connects Fractional Tube

Part No.	Tube O.D.				E Min	h		H		H ₁		F	F ₁	G	G ₁	l	L
	T		T ₁			in	mm	in	mm	in	mm						
	in	mm	in	mm													
03URU-02	3/16	4.76	1/8	3.17	2.3	7/16	11.11	1/2	12.70	7/16	11.11	13.7	12.7	16.0	15.2	23.4	36.6
04URU-02	1/4	6.35	1/8	3.17	2.3	1/2	12.70	9/16	14.28	7/16	11.11	15.2	12.7	17.8	15.2	24.6	38.6
04URU-03	1/4	6.35	3/16	4.76	3.0	1/2	12.70	9/16	14.28	1/2	12.70	15.2	13.7	17.8	16.0	25.4	39.4
05URU-02	5/16	7.93	1/8	3.17	2.3	9/16	14.28	5/8	15.87	7/16	11.11	16.3	12.7	18.5	15.2	25.9	39.9
05URU-04	5/16	7.93	1/4	6.35	4.8	9/16	14.28	5/8	15.87	9/16	14.28	16.3	15.2	18.5	17.8	27.4	42.2
06URU-02	3/8	9.52	1/8	3.17	2.3	5/8	15.87	11/16	17.46	7/16	11.11	16.8	12.7	19.3	15.2	26.9	40.9
06URU-04	3/8	9.52	1/4	6.35	4.8	5/8	15.87	11/16	17.46	9/16	14.28	16.8	15.2	19.3	17.8	28.4	43.2
06URU-05	3/8	9.52	5/16	7.93	6.4	5/8	15.87	11/16	17.46	5/8	15.87	16.8	16.3	19.3	18.5	29.5	44.2
08URU-02	1/2	12.70	1/8	3.17	2.3	13/16	20.63	7/8	22.22	7/16	11.11	22.9	12.7	21.8	15.2	28.4	45.2
08URU-04	1/2	12.70	1/4	6.35	4.8	13/16	20.63	7/8	22.22	9/16	14.28	22.9	15.2	21.8	17.8	29.5	47.0
08URU-06	1/2	12.70	3/8	9.52	7.0	13/16	20.63	7/8	22.22	11/16	17.46	22.9	16.8	17.8	19.3	31.0	48.5
10URU-06	5/8	15.87	3/8	9.52	7.0	15/16	23.81	1	25.40	11/16	17.46	24.4	16.8	21.8	19.3	31.8	49.3
10URU-08	5/8	15.87	1/2	12.70	10.0	15/16	23.81	1	25.40	7/8	22.22	24.4	22.9	21.8	21.8	31.8	52.1
12URU-04	3/4	19.05	1/4	6.35	4.8	1-1/16	26.98	1-1/8	28.57	9/16	14.28	24.4	15.2	21.8	17.8	31.8	49.3
12URU-06	3/4	19.05	3/8	9.52	7.0	1-1/16	26.98	1-1/8	28.57	11/16	17.46	24.4	16.8	21.8	19.3	33.3	50.8
12URU-08	3/4	19.05	1/2	12.70	10.0	1-1/16	26.98	1-1/8	28.57	7/8	22.22	24.4	22.9	21.8	21.8	33.3	53.6
12URU-10	3/4	19.05	5/8	15.87	12.0	1-1/16	26.98	1-1/8	28.57	1	25.40	24.4	24.4	21.8	21.8	33.3	53.6
16URU-08	1	25.40	1/2	12.70	10.0	1-3/8	34.92	1-1/2	38.10	7/8	22.22	31.2	22.9	26.4	21.8	40.9	63.2
16URU-12	1	25.40	3/4	19.05	16.0	1-3/8	34.92	1-1/2	38.10	1-1/8	28.57	31.2	24.4	26.4	21.8	40.4	62.7

Note : Dimensions are reference only, subject to change without prior notice. F,G and L are typical finger tight.

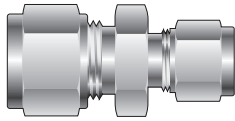

Reducing Union
URU

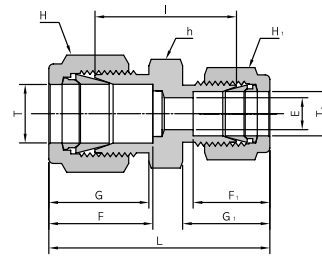

Connects Metric Tube

Part No.	Tube O.D.		E Min	h	H	H ₁	F	F ₁	G	G ₁	l	L
	T (mm)	T ₁ (mm)										
M06URU-M03	6	3	2.3	12.70	14.28	11.11	15.3	12.9	17.7	15.3	24.6	38.6
M06URU-M04	6	4	2.3	12.70	14.28	12.70	15.3	13.7	17.7	16.1	25.4	39.4
M08URU-M06	8	6	4.8	14.28	15.87	14.28	16.2	15.3	18.6	17.7	27.4	42.3
M10URU-M06	10	6	4.8	17.46	19.05	14.28	17.2	15.3	19.5	17.7	29.5	44.5
M10URU-M08	10	8	6.4	17.46	19.05	15.87	17.2	16.2	19.5	18.6	30.0	45.1
M12URU-M06	12	6	4.8	20.63	22.22	14.28	22.8	15.3	22.0	17.7	29.5	47.0
M12URU-M08	12	8	6.4	20.63	22.22	15.87	22.8	16.2	22.0	18.6	30.2	47.8
M12URU-M10	12	10	8.0	20.63	22.22	19.05	22.8	17.2	22.0	19.5	31.0	48.7
M16URU-M12	16	12	9.5	23.81	25.40	22.22	24.4	22.8	22.0	22.0	31.8	52.0
M25URU-M18	25	18	15.0	34.92	38.10	30.16	31.3	24.4	26.5	22.0	38.6	61.0
M25URU-M20	25	20	16.0	34.92	38.10	31.75	31.3	26.0	26.5	22.0	39.9	62.3

Connects Metric Tube to Fractional Tube

Part No.	Tube O.D.			E Min	h	H	H ₁	F	F ₁	G	G ₁	l	L
	T (mm)	In	T ₁ mm										
M03URU-02	3	1/8	3.17	2.3	11.11	11.11	11.11	12.9	12.8	15.3	15.2	22.1	35.2
M04URU-02	4	1/8	3.17	2.3	11.11	12.70	11.11	13.7	12.8	16.1	15.2	23.4	36.5
M04URU-04	4	1/4	6.35	2.3	14.28	12.70	14.28	13.7	15.3	16.1	17.7	25.4	39.4
M06URU-02	6	1/8	3.17	2.3	12.70	14.28	11.11	15.3	12.8	17.7	15.2	24.6	38.5
M06URU-04	6	1/4	6.35	4.8	12.70	14.28	14.28	15.3	15.8	17.7	17.7	26.2	41.0
M06URU-05	6	5/16	7.93	4.8	14.28	14.28	15.87	15.3	16.2	17.7	18.6	27.4	42.3
M08URU-04	8	1/4	6.35	4.8	14.28	15.87	14.28	16.2	15.3	18.6	17.7	27.4	42.3
M10URU-02	10	1/8	3.17	2.3	17.46	19.05	11.11	17.2	12.8	19.5	15.2	27.7	41.8
M10URU-04	10	1/4	6.35	4.8	17.46	19.05	14.28	17.2	15.3	19.5	17.7	29.5	44.5
M10URU-05	10	5/16	7.93	6.4	17.46	19.05	15.87	17.2	16.2	19.5	18.6	30.3	45.1
M10URU-06	10	3/8	9.52	7.0	17.46	19.05	17.46	17.2	16.9	19.5	18.6	31.0	45.9
M12URU-05	12	5/16	7.93	6.4	20.63	22.22	15.87	22.8	16.2	22.0	18.6	30.2	47.8
M12URU-06	12	3/8	9.52	7.0	20.63	22.22	17.46	22.8	16.9	22.0	19.2	31.0	48.4
M12URU-08	12	1/2	12.70	9.5	20.63	22.22	22.22	22.8	22.8	22.0	22.0	31.0	51.2
M15URU-08	15	1/2	12.70	10.0	23.81	25.40	22.22	24.4	22.8	22.0	22.0	31.8	52.0
M16URU-10	16	5/8	15.87	12.0	23.81	25.40	25.40	24.4	24.4	22.0	22.0	31.8	52.0
M18URU-12	18	3/4	19.05	15.0	26.98	30.16	28.57	24.4	24.4	22.0	22.0	33.3	53.5
M20URU-12	20	3/4	19.05	16.0	30.16	31.75	28.57	26.0	24.4	22.0	22.0	34.8	54.9
M20URU-16	20	1	25.40	16.0	34.92	31.75	38.10	26.0	31.2	22.0	26.4	38.0	60.3
M22URU-16	22	1	25.40	16.0	34.92	31.75	38.10	26.0	31.2	22.0	26.4	38.2	60.3

Note : Dimensions are reference only, subject to change without prior notice. F,G and L are typical finger tight.

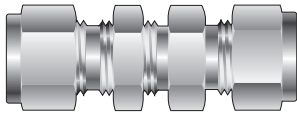

Bulkhead Union
UBU

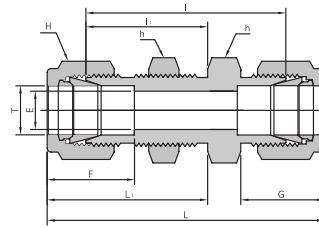

Connects Fractional Tube

Part No.	Tube O.D. T		E Min	h		H		F	G	l	l ₁	L	L ₁	Panel Hole Drill Size	Max Panel Thickn ess
	in	mm		in	mm	in	mm								
02UBU	1/8	3.17	2.3	1/2	12.70	7/16	11.11	12.7	15.2	38.1	24.6	51.3	31.2	8.3	12.7
03UBU	3/16	4.76	3.0	9/16	14.28	1/2	12.70	13.7	16.0	40.4	25.4	53.6	32.0	9.9	12.7
04UBU	1/4	6.35	4.8	5/8	15.87	9/16	14.28	15.2	17.8	42.9	26.2	57.7	33.5	11.5	10.2
05UBU	5/16	7.93	6.4	11/16	17.46	5/8	15.87	16.3	18.5	46.0	28.4	60.7	35.8	13.1	11.2
06UBU	3/8	9.52	7.0	3/4	19.05	11/16	17.46	16.8	19.3	47.5	29.5	62.2	36.8	14.7	11.2
08UBU	1/2	12.70	10.0	15/16	23.81	7/8	22.22	22.9	21.8	50.8	31.8	71.1	41.9	19.4	12.7
10UBU	5/8	15.87	12.0	1-1/16	26.98	1	25.40	24.4	21.8	52.3	32.5	72.6	42.7	22.6	12.7
12UBU	3/4	19.05	16.0	1-3/16	30.16	1-1/8	28.57	24.4	21.8	58.7	37.3	79.0	47.5	25.8	16.8
14UBU	7/8	22.22	18.0	1-3/8	34.92	1-1/4	31.75	25.9	21.8	64.3	42.9	84.6	53.1	29.0	19.1
16UBU	1	25.40	22.0	1-5/8	41.27	1-1/2	38.10	31.2	26.4	71.4	45.2	95.8	57.4	33.7	19.1

Connects Metric Tube

Part No.	Tube O.D. T(mm)	E Min	h	H	F	G	l	l ₁	L	L ₁	Panel Hole Drill Size	Max Panel Thickn ess
M03UBU	3	2.3	14.28	11.11	12.9	15.3	38.1	24.6	51.3	31.2	8.3	12.7
M04UBU	4	2.3	14.28	12.70	13.7	16.1	40.4	25.4	53.6	32.0	9.9	12.7
M06UBU	6	4.8	15.87	14.28	15.3	17.7	42.9	26.2	57.7	33.6	11.5	10.2
M08UBU	8	6.4	17.46	15.87	16.2	18.6	46.0	28.6	61.0	36.1	13.1	11.2
M10UBU	10	8.0	22.22	19.05	17.2	19.5	48.5	29.4	63.7	37.0	16.2	11.2
M12UBU	12	9.5	23.81	22.22	22.8	22.0	50.8	31.8	71.0	41.9	19.5	12.7
M15UBU	15	12.0	26.98	25.40	24.4	22.0	52.3	32.5	72.5	42.6	22.8	12.7
M16UBU	16	12.0	26.98	25.40	24.4	22.0	52.3	32.5	72.5	42.6	22.8	12.7
M18UBU	18	15.0	30.16	30.16	24.4	22.0	58.7	37.3	78.9	47.4	26.0	16.8

Note : Dimensions are reference only, subject to change without prior notice. F,G and L are typical finger tight.

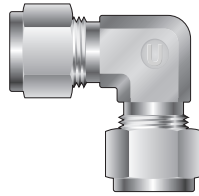

Union Elbow
UEU

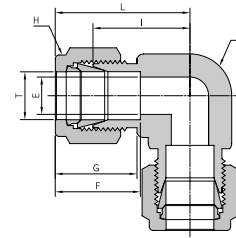

Connects Fractional Tube

Part No.	Tube O.D. T		E Min	h		H		F	G	l	L
	in	mm		in	mm	in	mm				
02UEU	1/8	3.17	2.3	7/16	11.11	7/16	11.11	12.7	15.2	15.7	22.4
03UEU	3/16	4.76	3.0	7/16	11.11	1/2	12.70	13.7	16.0	17.8	24.4
04UEU	1/4	6.35	4.8	1/2	12.70	9/16	14.27	15.2	17.8	19.6	26.9
05UEU	5/16	7.93	6.4	9/16	14.28	5/8	15.87	16.3	18.5	21.3	28.7
06UEU	3/8	9.52	7.0	5/8	15.87	11/16	17.46	16.8	19.3	23.1	30.5
08UEU	1/2	12.70	10.0	13/16	20.63	7/8	22.22	22.9	21.8	25.9	36.1
10UEU	5/8	15.87	12.0	1	25.40	1	25.40	24.4	21.8	28.7	38.9
12UEU	3/4	19.05	16.0	1-1/16	26.98	1-1/8	28.57	24.4	21.8	29.7	39.9
14UEU	7/8	22.22	18.0	1-1/4	31.75	1-1/4	31.75	25.9	21.8	34.5	44.7
16UEU	1	25.40	22.0	1-3/8	34.92	1-1/2	38.10	31.2	26.4	36.8	49.0

Connects Metric Tube

Part No.	Tube O.D. T(mm)	E Min	h	H	F	G	l	L
M03UEU	3	2.3	11.11	11.11	12.9	15.3	17.0	23.6
M04UEU	4	2.3	11.11	12.70	13.7	16.1	18.8	25.4
M06UEU	6	4.8	12.70	14.28	15.3	17.7	19.6	27.0
M08UEU	8	6.4	14.28	15.87	16.2	18.6	21.3	28.8
M10UEU	10	8.0	17.46	19.05	17.2	19.5	23.9	31.5
M12UEU	12	9.5	20.63	22.22	22.8	22.0	25.9	36.0
M15UEU	15	12.0	25.40	25.40	24.4	22.0	28.7	38.8
M16UEU	16	12.0	25.40	25.40	24.4	22.0	28.7	38.8
M18UEU	18	15.0	26.98	30.16	24.4	22.0	29.7	39.8
M20UEU	20	16.0	31.75	31.75	26.0	22.0	32.5	42.6
M22UEU	22	18.0	31.75	31.75	26.0	22.0	32.5	42.6
M25UEU	25	22.0	34.92	38.10	31.3	26.5	36.8	49.1

Note : Dimensions are reference only, subject to change without prior notice. F,G and L are typical finger tight.

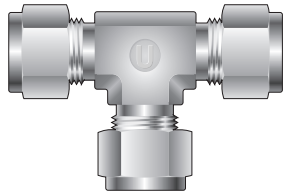

Union Tee
UUT

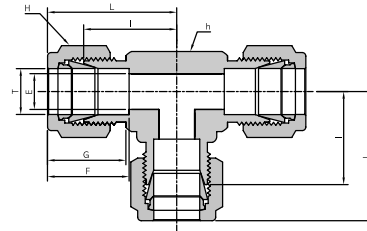

Connects Fractional Tube

Part No.	Tube O.D. T		E Min	h		H		F	G	l	L
	in	mm		in	mm	in	mm				
02UUT	1/8	3.17	2.3	7/16	11.11	7/16	11.11	12.7	15.2	15.7	22.4
03UUT	3/16	4.76	3.0	7/16	11.11	1/2	12.70	13.7	16.0	17.8	24.4
04UUT	1/4	6.35	4.8	1/2	12.70	9/16	14.28	15.2	17.8	19.6	26.9
05UUT	5/16	7.93	6.4	9/16	14.28	5/8	15.87	16.3	18.5	21.3	28.7
06UUT	3/8	9.52	7.0	5/8	15.87	11/16	17.46	16.8	19.3	23.1	30.5
08UUT	1/2	12.70	10.0	13/16	20.63	7/8	22.22	22.9	21.8	25.9	36.1
10UUT	5/8	15.87	12.0	1	25.40	1	25.40	24.4	21.8	28.7	38.9
12UUT	3/4	19.05	16.0	1-1/16	26.98	1-1/8	28.57	24.4	21.8	29.7	39.9
14UUT	7/8	22.22	18.0	1-1/4	31.75	1-1/4	31.75	25.9	21.8	34.5	44.7
16UUT	1	25.40	22.0	1-3/8	34.92	1-1/2	38.10	31.2	26.4	36.8	49.0

Connects Metric Tube

Part No.	Tube O.D. T(mm)	E Min	h	H	F	G	l	L
M03UUT	3	2.3	11.11	11.11	12.9	15.3	17.0	23.6
M04UUT	4	2.3	11.11	12.70	13.7	16.1	18.8	25.4
M06UUT	6	4.8	12.70	14.28	15.3	17.7	19.6	27.0
M08UUT	8	6.4	14.28	15.87	16.2	18.6	21.3	28.8
M10UUT	10	8.0	17.46	19.05	17.2	19.5	23.9	31.5
M12UUT	12	9.5	20.63	22.22	22.8	22.0	25.9	36.0
M15UUT	15	12.0	25.40	25.40	24.4	22.0	28.7	38.8
M16UUT	16	12.0	25.40	25.40	24.4	22.0	28.7	38.8
M18UUT	18	15.0	26.98	30.16	24.4	22.0	29.7	39.8
M20UUT	20	16.0	31.75	31.75	26.0	22.0	32.5	42.6
M22UUT	22	18.0	31.75	31.75	26.0	22.0	32.5	42.6
M25UUT	25	22.0	34.92	38.10	31.3	26.5	36.8	49.1

Note : Dimensions are reference only, subject to change without prior notice. F,G and L are typical finger tight.

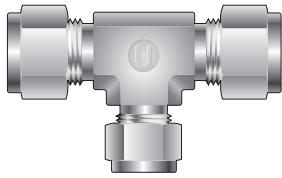

Reducing Union
Branch Tee
URBT

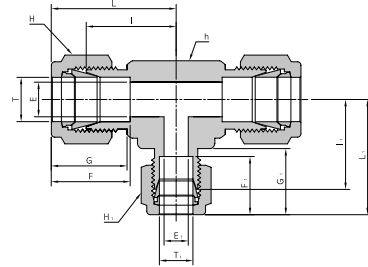

Connects Fractional Tube

Part No.	Tube O.D.				E Min	h		H		H ₁		F	F ₁	G	G ₁	l	l ₁	L	L ₁
	T		T ₁			in	mm	in	mm	in	mm								
06URBT-04	3/8	9.52	1/4	6.35	4.8	5/8	15.87	11/16	17.46	9/16	14.28	16.8	15.2	19.3	17.8	21.3	19.7	30.5	27.3
08URBT-04	1/2	12.70	1/4	6.35	4.8	13/16	20.63	13/16	20.63	9/16	14.28	22.9	15.2	21.8	17.8	25.9	24.3	36.1	31.9
08URBT-06	1/2	12.70	3/8	9.52	7.0	13/16	20.63	13/16	20.63	11/16	17.46	22.9	16.8	21.8	19.3	25.9	25.9	36.1	33.4
10URBT-06	5/8	15.87	3/8	9.52	7.0	1	25.40	1	25.40	11/16	17.46	24.4	16.8	21.8	19.3	28.7	28.7	38.9	36.2
12URBT-06	3/4	19.05	3/8	9.52	7.0	1-1/16	26.98	1-1/8	28.57	11/16	17.46	24.4	16.8	21.8	19.3	29.7	29.7	39.9	37.2
12URBT-08	3/4	19.05	1/2	12.70	10.0	1-1/16	26.98	1-1/8	28.57	7/8	22.22	24.4	22.9	21.8	21.8	29.7	29.7	39.9	39.7
16URBT-06	1	25.40	3/8	9.52	7.0	1-3/8	34.92	1-1/2	38.10	11/16	17.46	31.2	16.8	26.4	19.3	36.8	34.6	49.0	42.1
16URBT-08	1	25.40	1/2	12.70	10.0	1-3/8	34.92	1-1/2	38.10	7/8	22.22	31.2	22.9	26.4	21.8	36.8	34.6	49.0	44.6
16URBT-12	1	25.40	3/4	19.05	16.0	1-3/8	34.92	1-1/2	38.10	1-1/8	28.57	31.2	24.4	26.4	21.8	36.8	34.6	49.0	44.6

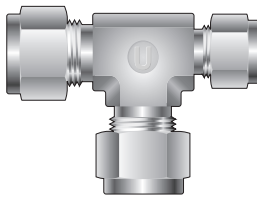

Reducing Union
Run Tee
URRT

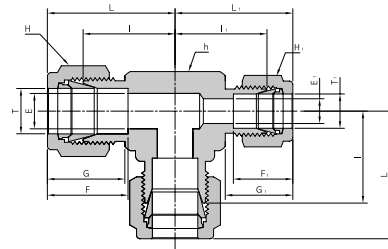

Connects Fractional Tube

Part No.	Tube O.D.				E Min	h		H		H ₁		F	F ₁	G	G ₁	l	l ₁	L	L ₁
	T		T ₁			in	mm	in	mm	in	mm								
06URRT-04	3/8	9.52	1/4	6.35	4.8	5/8	15.87	11/16	17.46	9/16	14.28	16.8	15.2	19.3	17.8	21.3	19.7	30.5	27.3
08URRT-04	1/2	12.70	1/4	6.35	4.8	13/16	20.63	13/16	20.63	9/16	14.28	22.9	15.2	21.8	17.8	25.9	24.3	36.1	31.9
08URRT-06	1/2	12.70	3/8	9.52	7.0	13/16	20.63	13/16	20.63	11/16	17.46	22.9	16.8	21.8	19.3	25.9	25.9	36.1	33.4
10URRT-06	5/8	15.87	3/8	9.52	7.0	1	25.40	1	25.40	11/16	17.46	24.4	16.8	21.8	19.3	28.7	28.7	38.9	36.2
12URRT-06	3/4	19.05	3/8	9.52	7.0	1-1/16	26.98	1-1/8	28.57	11/16	17.46	24.4	16.8	21.8	19.3	29.7	29.7	39.9	37.2
12URRT-08	3/4	19.05	1/2	12.70	10.0	1-1/16	26.98	1-1/8	28.57	7/8	22.22	24.4	22.9	21.8	21.8	29.7	29.7	39.9	39.7
16URRT-06	1	25.40	3/8	9.52	7.0	1-3/8	34.92	1-1/2	38.10	11/16	17.46	31.2	16.8	26.4	19.3	36.8	34.6	49.0	42.1
16URRT-08	1	25.40	1/2	12.70	10.0	1-3/8	34.92	1-1/2	38.10	7/8	22.22	31.2	22.9	26.4	21.8	36.8	34.6	49.0	44.6
16URRT-12	1	25.40	3/4	19.05	16.0	1-3/8	34.92	1-1/2	38.10	1-1/8	28.57	31.2	24.4	26.4	21.8	36.8	34.6	49.0	44.6

Note : Dimensions are reference only, subject to change without prior notice. F,G and L are typical finger tight.

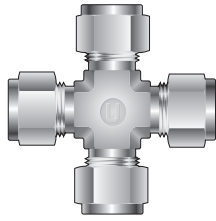

Union Cross
UUC

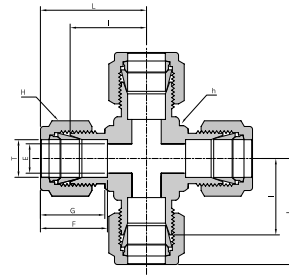

Connects Fractional Tube

Part No.	Tube O.D. T		E Min	h		H		F	G	l	L
	in	mm		in	mm	in	mm				
02UUC	1/8	3.17	2.3	3/8	9.52	7/16	11.11	12.7	15.2	15.7	22.4
03UUC	3/16	4.76	3.0	1/2	12.70	1/2	12.70	13.7	16.0	17.8	24.4
04UUC	1/4	6.35	4.8	1/2	12.70	9/16	14.28	15.2	17.8	19.6	26.9
05UUC	5/16	7.93	6.4	9/16	14.28	5/8	15.87	16.3	18.5	21.3	28.7
06UUC	3/8	9.52	7.0	5/8	15.87	11/16	17.46	16.8	19.3	23.1	30.5
08UUC	1/2	12.70	10.0	13/16	20.63	7/8	22.22	22.9	21.8	25.9	36.1
10UUC	5/8	15.87	12.0	15/16	23.81	1	25.40	24.4	21.8	28.7	38.8
12UUC	3/4	19.05	16.0	1-1/16	26.98	1-1/8	28.57	24.4	21.8	29.7	39.9
14UUC	7/8	22.22	18.0	1-1/4	31.75	1-1/4	31.75	25.9	21.8	34.5	44.7
16UUC	1	25.40	22.0	1-3/8	34.92	1-1/2	38.10	31.2	26.4	36.8	49.0

Connects Metric Tube

Part No.	Tube O.D. T(mm)	E Min	h	H	F	G	l	L
M03UUC	3	2.3	9.52	12.70	12.9	15.3	15.7	22.3
M06UUC	6	4.8	12.70	14.28	15.3	17.7	19.6	27.0
M08UUC	8	6.4	14.28	15.87	16.2	18.6	21.3	28.8
M10UUC	10	8.0	17.46	19.05	17.2	19.5	23.9	31.5
M12UUC	12	9.5	20.63	22.22	22.8	22.0	25.9	36.0
M16UUC	16	12.0	25.40	25.40	24.4	22.0	28.7	38.8
M18UUC	18	15.0	26.98	30.16	24.4	22.0	29.7	39.8
M20UUC	20	16.0	31.75	31.75	26.0	22.0	32.5	42.6
M25UUC	25	22.0	34.92	38.10	31.3	22.0	36.8	49.1

Note : Dimensions are reference only, subject to change without prior notice. F,G and L are typical finger tight.

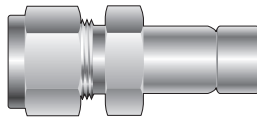

Reducer
UR

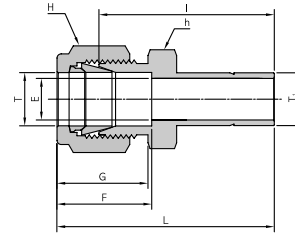

Connects Fractional Tube to Fractional Uni-Lok Port

Part No.	Tube O.D.				E Min	h		H		F	G	l	L
	T		T ₁			in	mm	in	mm				
	in	mm	in	mm									
02UR-02	1/8	3.17	1/8	3.17	2.0	7/16	11.11	7/16	11.11	12.7	15.2	26.9	33.5
02UR-03	1/8	3.17	3/16	4.76	2.3	7/16	11.11	7/16	11.11	12.7	15.2	27.7	34.3
02UR-04	1/8	3.17	1/4	6.35	2.3	7/16	11.11	7/16	11.11	12.7	15.2	29.5	36.1
02UR-06	1/8	3.17	3/8	9.52	2.3	7/16	11.11	7/16	11.11	12.7	15.2	31.0	37.6
02UR-08	1/8	3.17	1/2	12.70	2.3	9/16	14.28	7/16	11.11	12.7	15.2	37.6	44.2
03UR-02	3/16	4.76	1/8	3.17	2.0	7/16	11.11	1/2	12.70	13.7	16.0	28.2	34.8
03UR-04	3/16	4.76	1/4	6.35	3.0	7/16	11.11	1/2	12.70	13.7	16.0	30.5	37.8
04UR-02	1/4	6.35	1/8	3.17	2.0	1/2	12.70	9/16	14.28	15.2	17.8	29.5	36.8
04UR-03	1/4	6.35	3/16	4.76	3.0	1/2	12.70	9/16	14.28	15.2	17.8	30.2	37.6
04UR-04	1/4	6.35	1/4	6.35	4.8	1/2	12.70	9/16	14.28	15.2	17.8	31.8	39.1
04UR-05	1/4	6.35	5/16	7.93	4.8	1/2	12.70	9/16	14.28	15.2	17.8	32.5	39.9
04UR-06	1/4	6.35	3/8	9.52	4.8	1/2	12.70	9/16	14.28	15.2	17.8	33.3	40.6
04UR-08	1/4	6.65	1/2	12.70	4.8	9/16	14.28	9/16	14.28	15.2	17.8	38.9	46.2
04UR-10	1/4	6.35	5/8	15.87	4.8	11/16	17.46	9/16	14.28	15.2	17.8	40.6	48.0
04UR-12	1/4	6.35	3/4	19.05	4.8	13/16	20.63	9/16	14.28	15.2	17.8	40.4	47.8
05UR-06	5/16	7.93	3/8	9.52	6.4	9/16	14.28	5/8	15.87	16.3	18.5	34.5	41.9
05UR-08	5/16	7.93	1/2	12.70	6.4	9/16	14.28	5/8	15.87	16.3	18.5	40.1	47.5
06UR-04	3/8	9.52	1/4	6.35	4.8	5/8	15.87	11/16	17.46	16.8	19.3	34.0	41.4
06UR-06	3/8	9.52	3/8	9.52	7.0	5/8	15.87	11/16	17.46	16.8	19.3	35.8	43.2
06UR-08	3/8	9.52	1/2	12.70	7.0	5/8	15.87	11/16	17.46	16.8	19.3	41.1	48.5
06UR-10	3/8	9.52	5/8	15.87	7.0	11/16	17.46	11/16	17.46	16.8	19.3	42.9	50.3
06UR-12	3/8	9.52	3/4	19.05	7.0	13/16	20.63	11/16	17.46	16.8	19.3	42.9	50.3
08UR-04	1/2	12.70	1/4	6.35	4.8	13/16	20.63	7/8	22.22	22.9	21.8	34.8	45.0
08UR-06	1/2	12.70	3/8	9.52	7.0	13/16	20.63	7/8	22.22	22.9	21.8	36.6	46.7
08UR-08	1/2	12.70	1/2	12.70	10.0	13/16	20.63	7/8	22.22	22.9	21.8	42.2	52.3
08UR-10	1/2	12.70	5/8	15.87	10.0	13/16	20.63	7/8	22.22	22.9	21.8	43.7	53.8
08UR-12	1/2	12.70	3/4	19.05	10.0	13/16	20.63	7/8	22.22	22.9	21.8	43.7	53.8
08UR-16	1/2	12.70	1	25.40	10.0	1-1/16	26.98	7/8	22.22	22.9	21.8	50.0	60.2
10UR-12	5/8	15.87	3/4	19.05	12.0	15/16	23.81	1	25.40	24.4	21.8	44.5	54.6
10UR-14	5/8	15.87	7/8	22.22	12.0	15/16	23.81	1	25.40	24.4	21.8	46.0	56.1
10UR-16	5/8	15.87	1	25.40	12.0	1-1/16	26.98	1	25.40	24.4	21.8	50.8	61.0
12UR-08	3/4	19.05	1/2	12.70	10.0	1-1/16	26.98	1-1/8	28.57	24.4	21.8	44.5	54.6
12UR-16	3/4	19.05	1	25.40	16.0	1-1/16	26.98	1-1/8	28.57	24.4	21.8	52.3	62.5

Note : Dimensions are reference only, subject to change without prior notice. F,G and L are typical finger tight.

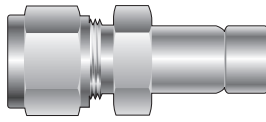

Reducer
UR

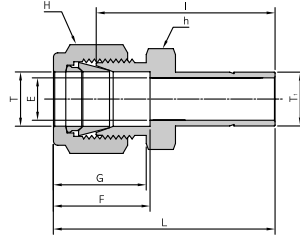

Connects Metric Tube to Metric Uni-Lok Port

Part No.	Tube O.D.		E Min	h	H	F	G	I	L
	T(mm)	T ₁ (mm)							
M03UR-M04	3	4	2.3	12.70	12.70	12.9	15.3	28.4	35.0
M03UR-M06	3	6	2.3	12.70	12.70	12.9	15.3	29.5	36.1
M06UR-M08	6	8	4.8	14.28	14.28	15.3	17.7	32.5	39.9
M06UR-M10	6	10	4.8	14.28	14.28	15.3	17.7	33.3	40.7
M06UR-M12	6	12	4.8	14.28	14.28	15.3	17.7	38.9	46.3
M08UR-M06	8	6	4.8	15.87	15.87	16.2	18.6	32.8	40.3
M08UR-M10	8	10	6.4	15.87	15.87	16.2	18.6	34.5	42.0
M08UR-M12	8	12	6.4	15.87	15.87	16.2	18.6	40.1	47.6
M10UR-M06	10	6	4.8	17.46	17.46	17.2	19.5	34.8	42.4
M10UR-M12	10	12	8.0	17.46	17.46	17.2	19.5	42.2	49.8
M12UR-M06	12	6	4.8	22.22	22.22	22.8	22.0	34.8	44.9
M12UR-M10	12	10	8.0	22.22	22.22	22.8	22.0	36.6	46.7
M12UR-M16	12	16	9.5	22.22	22.22	22.8	22.0	43.7	53.8
M12UR-M18	12	18	9.5	22.22	22.22	22.8	22.0	43.7	53.8
M16UR-M12	16	12	9.5	23.81	25.40	24.4	22.0	42.9	53.0
M18UR-M12	18	12	9.5	26.98	30.16	24.4	22.0	44.5	54.6
M18UR-M16	18	16	12.0	26.98	30.16	24.4	22.0	46.0	56.1
M20UR-M16	20	16	12.0	30.16	31.75	26.0	22.0	47.8	57.9
M20UR-M18	20	18	14.0	30.16	31.75	26.0	22.0	47.8	57.9
M22UR-M20	22	20	15.0	30.16	31.75	26.0	22.0	49.3	59.4
M22UR-M25	22	25	18.0	30.16	31.75	26.0	22.0	54.1	64.2
M25UR-M18	25	18	14.0	34.92	38.10	31.3	26.5	50.8	63.1
M25UR-M20	25	20	15.0	34.92	38.10	31.3	26.5	52.3	64.6

Connects Metric Tube to Fractional Uni-Lok Port

Part No.	Tube O.D.			E Min	h	H	F	G	I	L
	T(mm)	T ₁								
		In	mm							
M03UR-02	3	1/8	3.17	2.0	12.70	12.70	12.9	15.3	26.9	33.5
M03UR-04	3	1/4	6.35	2.4	12.70	12.70	12.9	15.3	29.5	36.1
M06UR-04	6	1/4	6.35	4.8	14.28	14.28	15.3	17.7	31.8	39.2
M06UR-05	6	5/16	7.93	4.8	14.28	14.28	15.3	17.7	32.5	39.9
M06UR-06	6	3/8	9.52	4.8	14.28	14.28	15.3	17.7	33.3	40.7
M06UR-08	6	1/2	12.70	4.8	14.28	14.28	15.3	17.7	38.9	46.3
M08UR-06	8	3/8	9.52	6.4	15.87	15.87	16.2	18.6	34.5	42.0
M08UR-08	8	1/2	12.70	6.4	15.87	15.87	16.2	18.6	40.1	47.6
M10UR-06	10	3/8	9.52	7.0	17.46	19.05	17.2	19.5	36.6	44.2
M10UR-08	10	1/2	12.70	8.0	17.46	19.05	17.2	19.5	42.2	49.8
M12UR-08	12	1/2	12.70	9.5	22.22	22.22	22.8	22.0	42.2	52.3
M12UR-12	12	3/4	19.05	9.5	22.22	22.22	22.8	22.0	43.7	53.8
M18UR-12	18	3/4	19.05	15.0	26.98	30.16	24.4	22.0	46.0	56.1
M18UR-16	18	1	25.40	15.0	26.98	30.16	24.4	22.0	52.3	62.4

Note : Dimensions are reference only, subject to change without prior notice. F, G and L are typical finger tight.

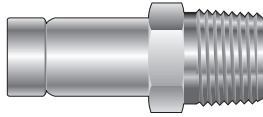

Male Adapter
UMA

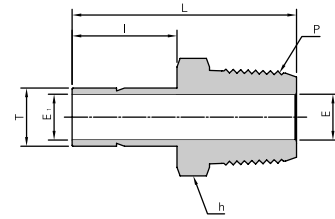

Connects Fractional Uni-Lok Port to Female NPT Thread

Part No.	Tube O.D. T		P (NPT)	E Min	E ₁	h		l	L
	in	mm				in	mm		
02UMA-02N	1/8	3.17	1/8	4.8	1.8	7/16	11.11	13.5	29.5
03UMA-02N	3/16	4.76	1/8	4.8	3.0	7/16	11.11	14.2	30.2
04UMA-02N	1/4	6.35	1/8	4.8	4.8	7/16	11.11	15.8	31.8
04UMA-04N	1/4	6.35	1/4	7.0	4.8	9/16	14.28	15.8	37.1
05UMA-02N	5/16	7.93	1/8	4.8	6.4	7/16	11.11	16.8	32.8
05UMA-04N	5/16	7.93	1/4	7.0	6.4	9/16	14.28	16.8	38.1
06UMA-04N	3/8	9.52	1/4	7.0	7.0	9/16	14.28	17.5	38.9
06UMA-06N	3/8	9.52	3/8	10.0	7.0	11/16	17.46	17.5	39.6
06UMA-08N	3/8	9.52	1/2	12.0	7.0	7/8	22.22	17.5	45.2
08UMA-04N	1/2	12.70	1/4	7.0	10.0	9/16	14.28	23.2	44.5
08UMA-06N	1/2	12.70	3/8	10.0	10.0	11/16	17.46	23.2	45.2
08UMA-08N	1/2	12.70	1/2	12.0	10.0	7/8	22.22	23.2	50.5
10UMA-08N	5/8	15.87	1/2	12.0	12.0	7/8	22.22	24.7	52.3
12UMA-12N	3/4	19.05	3/4	18.0	15.0	1-1/16	26.98	24.7	52.3
14UMA-12N	7/8	22.22	3/4	18.0	17.0	1-1/16	26.98	26.7	54.3
16UMA-16N	1	25.40	1	22.0	20.0	1-3/8	34.92	31.7	66.0

Female ISO Tapered Threads are available for all fractional UMA. Add "R" as a suffix instead of "N".

Connects Metric Uni-Lok Port to Female ISO Tapered Thread

Part No.	Tube O.D. T(mm)	P (PT)	E Min	E ₁	h	l	L
M03UMA-02R	3	1/8	4.0	1.8	12.70	13.2	29.4
M06UMA-02R	6	1/8	4.8	4.8	12.70	15.8	32.8
M06UMA-04R	6	1/4	4.8	4.8	14.28	15.8	38.1
M08UMA-04R	8	1/4	6.4	6.4	14.28	16.5	39.1
M10UMA-04R	10	1/4	8.0	8.0	14.28	17.5	39.9
M10UMA-06R	10	3/8	8.0	8.0	17.46	17.5	40.6
M10UMA-08R	10	1/2	12.0	8.0	22.22	17.5	45.2
M12UMA-04R	12	1/4	7.0	9.0	14.28	23.5	46.5
M12UMA-06R	12	3/8	9.0	9.0	17.46	23.5	46.2
M12UMA-08R	12	1/2	12.0	9.0	22.22	23.5	51.8
M18UMA-08R	18	1/2	12.0	14.0	22.22	24.9	53.2
M18UMA-12R	18	3/4	16.0	14.0	26.98	24.9	53.2

Female NPT Threads are available for all metric UMA. Add "N" as a suffix instead of "R".

Note : Dimensions are reference only, subject to change without prior notice. F,G and L are typical finger tight.

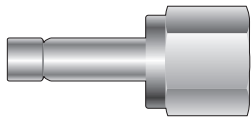

Female Adapter
UFA

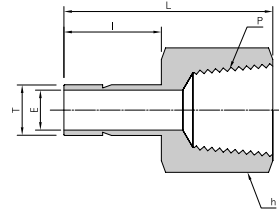

Connects Fractional Uni-Lok Port to Male NPT Thread

Part No.	Tube O.D. T		P (NPT)	E Min	h		l	L
	In	mm			In	mm		
02UFA-02N	1/8	3.17	1/8	1.8	9/16	14.28	13.5	31.5
02UFA-04N	1/8	3.17	1/4	1.8	3/4	19.05	13.5	35.3
03UFA-02N	3/16	4.76	1/8	3.0	9/16	14.28	14.2	32.0
03UFA-04N	3/16	4.76	1/4	3.0	3/4	19.05	14.2	35.8
04UFA-02N	1/4	6.35	1/8	4.8	9/16	14.28	15.8	33.0
04UFA-04N	1/4	6.35	1/4	4.8	3/4	19.05	15.8	37.1
04UFA-06N	1/4	6.35	3/8	4.8	7/8	22.22	15.8	39.8
04UFA-08N	1/4	6.35	1/2	4.8	1-1/16	26.98	15.8	45.5
05UFA-02N	5/16	7.93	1/8	6.4	9/16	14.28	16.8	34.3
05UFA-04N	5/16	7.93	1/4	6.4	3/4	19.05	16.8	37.6
06UFA-02N	3/8	9.52	1/8	7.0	9/16	14.28	17.5	34.3
06UFA-04N	3/8	9.52	1/4	7.0	3/4	19.05	17.5	38.1
06UFA-06N	3/8	9.52	3/8	7.0	7/8	22.22	17.5	40.4
06UFA-08N	3/8	9.52	1/2	7.0	1-1/16	26.98	17.5	46.7
08UFA-04N	1/2	12.70	1/4	10.0	3/4	19.05	23.2	43.4
08UFA-06N	1/2	12.70	3/8	10.0	7/8	22.22	23.2	45.5
08UFA-08N	1/2	12.70	1/2	10.0	1-1/16	26.98	23.2	51.8
10UFA-06N	5/8	15.87	3/8	12.0	7/8	22.22	24.7	48.3
10UFA-08N	5/8	15.87	1/2	12.0	1-1/16	26.98	24.7	53.8
10UFA-12N	5/8	15.87	3/4	12.0	1-1/4	31.75	24.7	55.4
12UFA-08N	3/4	19.05	1/2	15.0	1-1/16	26.98	24.7	52.8
12UFA-12N	3/4	19.05	3/4	15.0	1-1/4	31.75	24.7	54.9
12UFA-16N	3/4	19.05	1	15.0	1-5/8	41.27	24.7	58.4
14UFA-12N	7/8	22.22	3/4	17.0	1-1/4	31.75	26.7	57.2
16UFA-12N	1	25.40	3/4	20.0	1-1/4	31.75	31.7	60.7
16UFA-16N	1	25.40	1	20.0	1-5/8	41.27	31.7	64.3

Female ISO Tapered Threads are available for all fractional UFA. Add "R" as a suffix instead of "N".

Connects Metric Uni-Lok Port to Female ISO Tapered Thread

Part No.	Tube O.D. T(mm)	P (PT)	E Min	h	l	L
M03UFA-02R	3	1/8	1.8	14.28	13.2	31.2
M06UFA-02R	6	1/8	4.8	14.28	15.8	32.5
M06UFA-04R	6	1/4	4.8	19.05	15.8	37.1
M08UFA-04R	8	1/4	6.4	19.05	16.5	37.6
M10UFA-04R	10	1/4	8.0	19.05	17.5	38.1
M10UFA-06R	10	3/8	8.0	22.22	17.5	40.1
M10UFA-08R	10	1/2	8.0	26.98	17.5	46.5
M12UFA-04R	12	1/4	9.0	19.05	23.5	43.7
M12UFA-06R	12	3/8	9.0	22.22	23.5	46.0
M12UFA-08R	12	1/2	9.0	26.98	23.5	52.3
M18UFA-12R	18	3/4	14.0	31.75	24.9	54.8

Female NPT Threads are available for all metric UFA. Add "N" as a suffix instead of "R".

Note : Dimensions are reference only, subject to change without prior notice. F, G and L are typical finger tight.

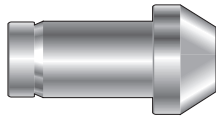

Port Connector
UPC

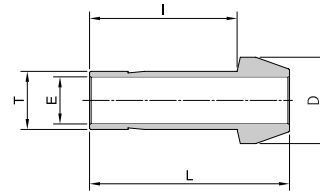

Connects Fractional Uni-Lok Port

Part No.	Tube O.D. T		E Min	D	l	L
	in	mm				
UPC-02	1/8	3.17	1.8	6.1	15.8	22.4
UPC-04	1/4	6.35	4.8	9.4	18.8	24.6
UPC-05	5/16	7.93	6.4	10.9	20.1	25.9
UPC-06	3/8	9.52	7.0	12.7	20.3	26.2
UPC-08	1/2	12.70	10.0	15.7	25.9	35.8
UPC-12	3/4	19.05	15.0	22.1	27.7	37.4
UPC-16	1	25.40	20.0	28.4	34.5	48.3

Connects Metric Uni-Lok Port

Part No.	Tube O.D. T(mm)	E Min	D	l	L
UPC-M03	3	2.0	6.0	15.7	22.2
UPC-M06	6	4.8	9.0	18.7	24.6
UPC-M08	8	6.4	11.0	20.0	25.9
UPC-M10	10	8.0	13.1	20.2	26.1
UPC-M12	12	9.0	15.0	26.0	35.8
UPC-M16	16	12.0	19.0	27.6	37.4

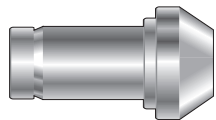

*Reducing
Port Connector*
URPC

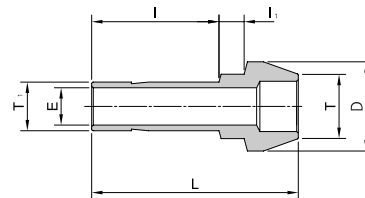

Connects Fractional Uni-Lok Port

Part No.	Tube O.D.				E Min	D	l	l ₁	L
	T		T ₁						
	in	mm	in	mm					
04URPC-02	1/4	6.35	1/8	3.17	2.3	9.4	13.5	3.3	22.6
06URPC-02	3/8	9.52	1/8	3.17	2.3	12.7	13.5	3.8	23.1
06URPC-04	3/8	9.52	1/4	6.35	4.8	12.7	15.8	3.3	24.9
08URPC-04	1/2	12.70	1/4	6.35	4.8	15.7	15.8	3.8	29.2
08URPC-06	1/2	12.70	3/8	9.52	7.0	15.7	17.5	3.3	30.5
12URPC-08	3/4	19.05	1/2	12.70	10.0	22.1	23.2	3.8	36.6

Connects Metric Uni-Lok Port

Part No.	Tube O.D.		E Min	D	l	l ₁	L
	T	T ₁					
M06URPC-M03	6	3	2.3	9.0	13.5	3.2	22.6
M08URPC-M06	8	6	4.8	11.0	15.7	3.1	24.7
M10URPC-M06	10	6	4.8	13.1	15.7	3.4	25.0
M12URPC-M06	12	6	4.8	15.0	15.7	3.6	29.1
M12URPC-M10	12	10	8.0	15.0	17.5	3.1	30.4
M16URPC-M12	16	12	9.0	19.0	23.1	3.4	36.2

Note : Dimensions are reference only, subject to change without prior notice. F,G and L are typical finger tight.

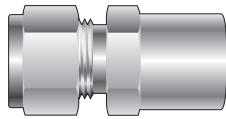

Male Pipe
Weld Connector
UPCW

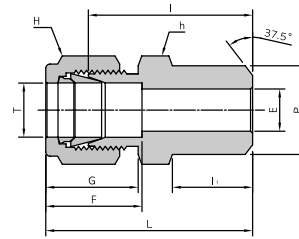

Connects Fractional Tube to Pipe

Part No.	Tube O.D. T		Pipe Weld size P		E Min	h		H		F	G	l	l ₁	L
	in	mm	Nom	O.D.		in	mm	in	mm					
02UPCW-02P	1/8	3.17	1/8	10.30	2.3	7/16	11.11	7/16	11.11	12.7	15.2	23.9	9.7	30.5
03UPCW-02P	3/16	4.76	1/8	10.30	3.0	7/16	11.11	1/2	12.70	13.7	16.0	24.6	9.7	31.2
04UPCW-02P	1/4	6.35	1/8	10.30	4.8	1/2	12.70	9/16	14.28	15.2	17.8	25.4	9.7	32.8
04UPCW-04P	1/4	6.35	1/4	13.70	4.8	9/16	14.28	9/16	14.28	15.2	17.8	30.5	14.2	37.8
05UPCW-02P	5/16	7.93	1/8	10.30	5.0	9/16	14.28	5/8	15.87	16.3	18.5	26.7	9.7	34.0
05UPCW-04P	5/16	7.93	1/4	13.70	6.4	9/16	14.28	5/8	15.87	16.3	18.5	31.2	14.2	38.6
06UPCW-04P	3/8	9.52	1/4	13.70	7.0	5/8	15.87	11/16	17.46	16.8	19.3	32.5	14.2	39.9
06UPCW-06P	3/8	9.52	3/8	17.10	7.0	11/16	17.46	11/16	17.46	16.8	19.3	32.5	14.2	39.9
06UPCW-08P	3/8	9.52	1/2	21.30	7.0	7/8	22.22	11/16	17.46	16.8	19.3	38.9	19.1	46.2
08UPCW-06P	1/2	12.70	3/8	17.10	10.0	13/16	20.63	7/8	22.22	22.9	21.8	33.3	14.2	43.4
08UPCW-08P	1/2	12.70	1/2	21.30	10.0	7/8	22.22	7/8	22.22	22.9	21.8	38.9	19.1	49.0
08UPCW-12P	1/2	12.70	3/4	26.67	10.0	1-1/16	26.98	7/8	22.22	22.9	21.8	40.4	19.1	50.5
10UPCW-08P	5/8	15.87	1/2	21.30	12.0	15/16	23.81	1	25.40	24.4	21.8	38.9	19.1	49.0
12UPCW-12P	3/4	19.05	3/4	26.67	16.0	1-1/16	26.98	1-1/8	28.57	24.4	21.8	40.4	19.1	50.5
16UPCW-16P	1	25.40	1	33.40	22.0	1-3/8	34.92	1-1/2	38.10	31.2	26.4	50.0	23.9	62.2

Connects Metric Tube to Pipe

Part No.	Tube O.D. T(mm)	Pipe Weld Size P		E Min	h	H	F	G	l	l ₁	L
		Nom	O.D.								
M03UPCW-02P	3	1/8	10.3	2.3	12.70	12.70	12.9	15.3	23.1	9.7	29.7
M04UPCW-02P	4	1/8	10.3	2.3	12.70	12.70	13.7	16.1	24.1	9.7	30.7
M06UPCW-02P	6	1/8	10.3	4.8	14.28	14.28	15.3	17.7	25.4	9.7	32.8
M06UPCW-04P	6	1/4	13.7	4.8	14.28	14.28	15.3	17.7	30.2	14.2	37.6
M08UPCW-02P	8	1/8	10.3	4.8	15.87	15.87	16.2	18.6	26.7	9.7	34.2
M08UPCW-04P	8	1/4	13.7	6.4	15.87	15.87	16.2	18.6	31.2	14.2	38.7
M08UPCW-08P	8	1/2	21.3	6.4	22.22	15.87	16.2	18.6	37.3	19.0	44.8
M10UPCW-04P	10	1/4	13.7	7.0	17.46	19.05	17.2	19.5	33.3	14.2	40.9
M10UPCW-06P	10	3/8	17.1	8.0	17.46	19.05	17.2	19.5	32.5	14.2	40.1
M10UPCW-08P	10	1/2	21.3	8.0	22.22	19.05	17.2	19.5	38.1	19.0	45.7
M12UPCW-04P	12	1/4	13.7	7.0	22.22	22.22	22.8	22.0	33.3	14.2	43.4
M12UPCW-06P	12	3/8	17.1	9.5	22.22	22.22	22.8	22.0	33.3	14.2	43.4
M12UPCW-08P	12	1/2	21.3	9.5	22.22	22.22	22.8	22.0	38.1	19.0	48.2
M15UPCW-08P	15	1/2	21.3	12.0	23.81	25.40	24.4	22.0	38.9	19.0	49.0
M16UPCW-08P	16	1/2	21.3	12.0	23.81	25.40	24.4	22.0	38.9	19.0	49.0
M18UPCW-08P	18	1/2	21.3	15.0	26.98	30.16	24.4	22.0	40.4	19.0	50.5

Note : Dimensions are reference only, subject to change without prior notice. F,G and L are typical finger tight.

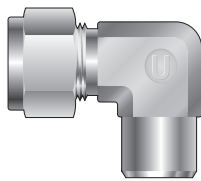

*Male Pipe
Weld Elbow*
UPEW

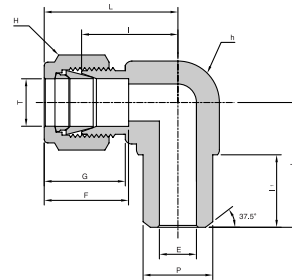

Connects Fractional Tube to Pipe

Part No.	Tube O.D. T		Pipe Weld size P		E Min	h		H		F	G	l	l ₁	L	L ₁
	in	mm	Nom	O.D.		in	mm	in	mm						
02UPEW-02P	1/8	3.17	1/8	10.30	4.8	1/2	12.70	9/16	14.28	15.2	17.8	19.6	9.7	26.9	18.8
04UPEW-04P	1/4	6.35	1/4	13.70	4.8	1/2	12.70	9/16	14.28	15.2	17.8	19.6	14.2	26.9	23.4
06UPEW-04P	3/8	9.52	1/4	13.70	7.0	5/8	15.87	11/16	17.46	16.8	19.3	23.1	14.2	30.5	25.4
08UPEW-08P	1/2	12.70	1/2	21.30	10.0	13/16	20.63	7/8	22.22	22.9	21.8	25.9	19.1	36.1	33.0
12UPEW-12P	3/4	19.05	3/4	26.67	16.0	1-1/16	26.98	1-1/8	28.57	24.4	21.8	29.7	19.1	39.9	36.8

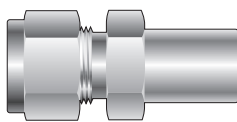

*Tube Socket
Weld Connector*
UPCSW

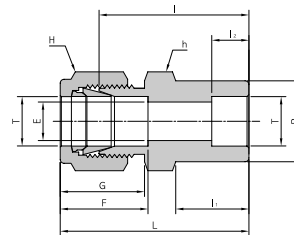

Connects Fractional Tube

Part No.	Tube O.D. T		E Min	P	h		H		F	G	l	l ₁	l ₂	L
	in	mm			in	mm	in	mm						
02UPCSW-02P	1/8	3.17	2.3	7.8	7/16	11.11	7/16	11.11	12.7	15.2	22.4	8.6	6.4	29.0
04UPCSW-04P	1/4	6.35	4.8	11.2	1/2	12.70	9/16	14.28	15.2	17.8	26.2	10.4	7.9	33.5
06UPCSW-06P	3/8	9.52	7.0	15.7	5/8	15.87	11/16	17.46	16.8	19.3	30.2	11.9	9.7	37.6
08UPCSW-08P	1/2	12.70	10.0	19.0	13/16	20.63	7/8	22.22	22.9	21.8	31.0	11.9	12.7	41.1
12UPCSW-12P	3/4	19.05	16.0	26.7	1-1/16	26.98	1-1/8	28.57	24.4	21.8	33.3	11.9	14.2	43.4
16UPCSW-16P	1	25.40	22.0	33.3	1-3/8	34.92	1-1/2	38.10	31.2	26.4	40.4	14.2	19.1	52.6

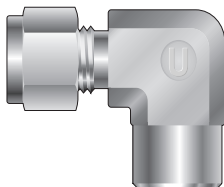

*Tube Socket
Weld Connector*
UPESW

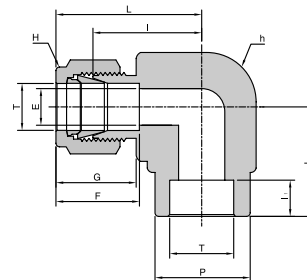

Connects Fractional Tube

Part No.	Tube O.D. T		E Min	P	h		H		F	G	l	l ₁	l ₂	L	L ₁
	in	mm			in	mm	in	mm							
04UPESW-04P	1/4	6.35	4.8	12.70	1/2	12.70	9/16	14.28	15.2	17.8	19.6	7.9	26.9	19.6	19.6
06UPESW-06P	3/8	9.52	7.0	15.7	5/8	15.87	11/16	17.46	16.8	19.3	23.1	9.7	30.5	23.1	23.1
08UPESW-08P	1/2	12.70	10.0	20.6	13/16	20.63	7/8	22.22	22.9	21.8	25.9	12.7	36.1	25.9	25.9

Note : Dimensions are reference only, subject to change without prior notice. F, G and L are typical finger tight.

Tube Fittings • UUA/UBUA/UAA

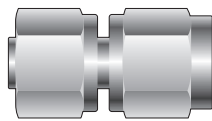

AN Union
UUA

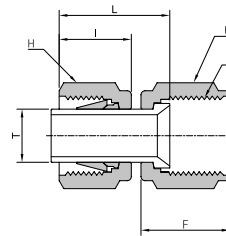

Connects Fractional Tube to AN Flared Tube

Part No.	Tube O.D. T		AN Tube Flare Size		Straight Thread P(U)	E Min	h		H		F	G	l	L
	in	mm	in	mm			in	mm	in	mm				
02UUA-02	1/8	3.17	1/8	3.17	5/16-24	1.5	7/16	11.11	7/16	11.11	12.7	15.2	24.9	31.5
02UUA-04	1/8	3.17	1/4	6.35	7/16-20	2.3	1/2	12.70	7/16	11.11	12.7	15.2	28.4	35.1
04UUA-04	1/4	6.35	1/4	6.35	7/16-20	4.3	1/2	12.70	9/16	14.28	15.2	17.8	30.2	37.6
05UUA-05	5/16	7.93	5/16	7.93	1/2-20	5.8	9/16	14.28	5/8	15.87	16.3	18.5	31.0	38.4
06UUA-04	3/8	9.52	1/4	6.35	7/16-20	4.3	5/8	15.87	11/16	17.46	16.8	19.3	32.3	39.6
06UUA-06	3/8	9.52	3/8	9.52	9/16-18	7.0	5/8	15.87	11/16	17.46	16.8	19.3	32.3	39.6
08UUA-08	1/2	12.70	1/2	12.70	3/4-16	10.0	13/16	20.63	7/8	22.22	22.9	21.8	35.8	46.0
12UUA-12	3/4	19.05	3/4	19.05	1-1/16-12	15.5	1-1/8	28.57	1-1/8	28.57	24.4	21.8	43.2	53.3
16UUA-16	1	25.40	1	25.40	1-5/16-12	21.3	1-3/8	34.92	1-1/2	38.10	31.2	26.4	49.3	61.5

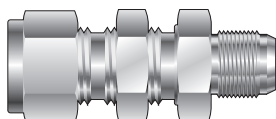

AN Bulkhead Union
UBUA

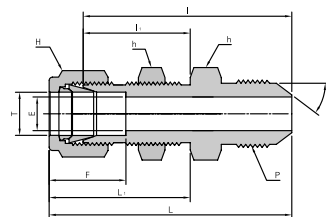

Connects Fractional Tube to AN Flared Tube

Part No.	Tube O.D. T		AN Tube Flare Size		Straight Thread P(U)	E Min	h		H		F	l	l ₁	L	L ₁	Panel Hole Drill Size	Max Panel Thickness
	in	mm	in	mm			in	mm	in	mm							
04UBUA-04	1/4	6.35	1/4	6.35	7/16-20	4.3	5/8	15.87	9/16	14.28	15.2	46.5	26.2	53.8	33.5	11.5	10.2
06UBUA-06	3/8	9.52	3/8	9.52	9/16-18	7.0	3/4	19.05	11/16	17.46	16.8	49.8	29.5	57.2	36.8	14.7	11.2
08UBUA-08	1/2	12.70	1/2	12.70	3/4-16	10.0	15/16	23.81	7/8	22.22	22.9	55.6	31.8	65.8	41.9	19.4	12.7
12UBUA-12	3/4	19.05	3/4	19.05	1-1/16-12	15.5	1-3/16	30.16	1-1/8	28.57	24.4	68.8	37.3	79.0	47.5	25.8	16.8
16UBUA-16	1	25.40	1	25.40	1-5/16-12	21.3	1/5-8	41.27	1-1/2	38.10	31.2	80.3	45.2	92.5	57.4	33.7	19.1

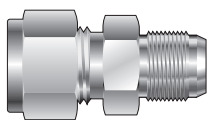

AN Adapter
UAA

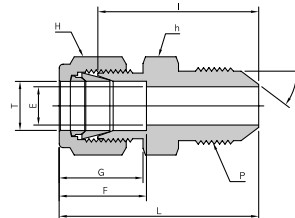

Connects Fractional Tube to AN Flared Tube

Part No.	Tube O.D. T		AN Tube Flare Size		Straight Thread P(U)	h		H		F	l	L
	in	mm	in	mm		in	mm	in	mm			
02UAA-02	1/8	3.17	1/8	3.17	5/16-24	3/8	9.52	7/16	11.11	13.7	13.5	18.5
02UAA-04	1/8	3.17	1/4	6.35	7/16-20	9/16	14.28	7/16	11.11	15.7	13.5	19.1
04UAA-04	1/4	6.35	1/4	6.35	7/16-20	9/16	14.28	9/16	14.28	15.7	15.7	21.3
06UAA-06	3/8	9.52	3/8	9.52	9/16-18	11/16	17.46	11/16	17.46	18.3	17.5	24.9
08UAA-08	1/2	12.70	1/2	12.70	3/4-16	7/8	22.22	7/8	22.22	21.6	23.1	31.8

Note : Dimensions are reference only, subject to change without prior notice. F,G and L are typical finger tight.

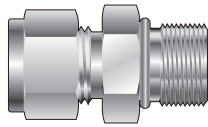

SAE Male Connector
UMCS

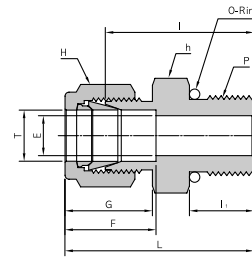

Connects Fractional Tube to SAE Straight Thread Boss

Part No.	Tube O.D. T		Straight Thread P(U)	E Min	h		H		F	G	l	l ₁	L
	in	mm			in	mm	in	mm					
02UMCS-02U	1/8	3.17	5/16-24	2.3	7/16	11.11	7/16	11.11	12.7	15.2	23.3	7.6	30.0
04UMCS-04U	1/4	6.35	7/16-20	4.8	9/16	14.28	9/16	14.28	15.2	17.8	26.7	9.1	34.0
04UMCS-06U	1/4	6.35	9/16-18	4.8	11/16	17.46	9/16	14.28	15.2	17.8	28.2	9.9	35.6
04UMCS-08U	1/4	6.35	3/4-16	4.8	7/8	22.22	9/16	14.28	15.2	17.8	30.2	11.2	37.6
04UMCS-10U	1/4	6.35	7/8-14	4.8	1	25.40	9/16	14.28	15.2	17.8	33.3	12.7	40.6
05UMCS-05U	5/16	7.93	1/2-20	6.0	5/8	15.87	5/8	15.87	16.3	18.5	27.4	9.1	34.8
06UMCS-04U	3/8	9.52	7/16-20	5.0	5/8	15.87	11/16	17.46	16.8	19.3	28.2	9.1	35.6
06UMCS-06U	3/8	9.52	9/16-18	7.0	11/16	17.46	11/16	17.46	16.8	19.3	29.7	9.9	37.1
06UMCS-08U	3/8	9.52	3/4-16	7.0	7/8	22.22	11/16	17.46	16.8	19.3	31.8	11.2	39.1
06UMCS-10U	3/8	9.52	7/8-14	7.0	1	25.40	11/16	17.46	16.8	19.3	34.8	12.7	42.2
08UMCS-06U	1/2	12.70	9/16-18	7.0	13/16	20.63	7/8	22.22	22.9	21.8	29.0	9.9	39.1
08UMCS-08U	1/2	12.70	3/4-16	10.0	7/8	22.22	7/8	22.22	22.9	21.8	31.8	11.2	41.9
08UMCS-10U	1/2	12.70	7/8-14	10.0	1	25.40	7/8	22.22	22.9	21.8	34.8	12.7	45.0
08UMCS-12U	1/2	12.70	1-1/16-12	10.0	1-1/4	31.75	7/8	22.22	22.9	21.8	38.9	15.0	49.0
10UMCS-08U	5/8	15.87	3/4-16	10.0	15/16	23.81	1	25.40	24.4	21.8	31.8	11.2	41.9
10UMCS-10U	5/8	15.87	7/8-14	12.0	1	25.40	1	25.40	24.4	21.8	35.1	12.7	45.2
12UMCS-08U	3/4	19.05	3/4-16	10.0	1-1/16	26.98	1-1/8	28.57	24.4	21.8	35.8	11.2	46.0
12UMCS-12U	3/4	19.05	1-1/16-12	16.0	1-1/4	31.80	1-1/8	28.57	24.4	21.8	38.9	15.0	49.0
14UMCS-14U	7/8	22.22	1-3/16-12	18.0	1-3/8	34.92	1-1/4	31.75	25.9	21.8	38.9	15.0	49.0
16UMCS-12U	1	25.40	1-1/16-12	16.0	1-3/8	34.92	1-1/2	38.10	31.2	26.4	41.1	15.0	53.3
16UMCS-16U	1	25.40	1-5/16-12	22.0	1-1/2	38.10	1-1/2	38.10	31.2	26.4	42.2	15.0	54.4

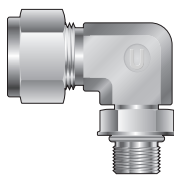

Positionable SAE Male Elbow
UMES

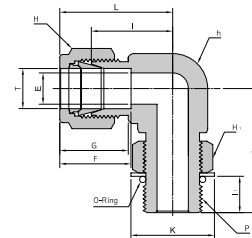

Connects Fractional Tube to SAE Straight Thread Boss

Part No.	Tube O.D. T		Straight Thread P(U)	E min	h		H		H ₁		F	G	l	l ₁	L	L ₁	K
	in	mm			in	mm	in	mm	in	mm							
04UMES-04U	1/4	6.35	7/16-20	4.8	1/2	12.70	9/16	14.28	9/16	14.28	15.2	17.8	21.1	9.9	28.4	28.4	16.5
05UMES-05U	5/16	7.93	1/2-20	6.0	9/16	14.28	5/8	15.87	5/8	15.87	16.2	18.5	22.9	9.9	30.2	29.5	18.3
06UMES-06U	3/8	9.52	9/16-18	7.0	5/8	15.87	11/16	17.46	11/16	17.46	16.8	19.3	24.6	11.2	32.0	32.3	20.1
06UMES-08U	3/8	9.52	3/4-16	7.0	13/16	20.63	11/16	17.46	7/8	22.22	16.8	19.3	27.4	12.7	34.8	37.8	25.7
08UMES-08U	1/2	12.70	3/4-16	10.0	13/16	20.63	7/8	22.22	7/8	22.22	22.9	21.8	27.4	12.7	37.6	37.8	25.7
10UMES-10U	5/8	15.87	7/8-14	12.0	1	25.40	1	25.40	1	25.40	24.9	21.8	29.5	14.2	39.6	43.4	29.5
12UMES-12U	3/4	19.05	1-1/16-12	16.0	1-1/16	26.98	1-1/8	28.57	1-1/4	31.75	24.9	21.8	31.2	16.8	41.4	48.8	36.6
14UMES-14U	7/8	22.22	1-3/16-12	18.0	1-1/4	31.75	1-1/4	31.75	1-3/8	34.92	25.9	21.8	33.0	16.8	43.2	50.6	40.4
16UMES-16U	1	25.40	1-5/16-12	22.0	1-3/8	34.92	1-1/2	38.10	1-1/2	38.10	31.2	26.4	38.4	16.8	50.5	53.6	43.9

Note : Dimensions are reference only, subject to change without prior notice. F, G and L are typical finger tight.

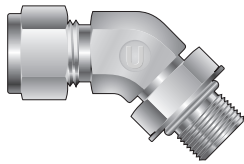

*Positionable
SAE 45° Elbow*
UMVES

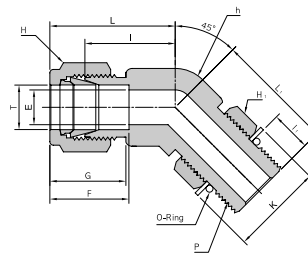

Connects Fractional Tube to SAE Straight Thread Boss

Part No.	Tube O.D. T		Straight Thread P(U)	E Min	h		H		H ₁		F	G	l	l ₁	L	L ₁	K
	in	mm			in	mm	in	mm	in	mm							
04UMVES-04U	1/4	6.35	7/16-20	4.8	1/2	12.70	9/16	14.28	9/16	14.28	15.2	17.8	18.3	9.9	25.7	25.7	16.5
06UMVES-06U	3/8	9.52	9/16-18	7.0	5/8	15.87	11/16	17.46	11/16	17.46	16.8	19.3	20.6	11.2	27.9	28.2	20.1
08UMVES-08U	1/2	12.70	3/4-16	10.0	13/16	20.63	7/8	22.22	7/8	22.22	22.9	21.8	21.8	12.7	32.0	32.3	25.7
12UMVES-12U	3/4	19.05	1-1/16-12	16.0	1-1/8	28.57	1-1/8	28.57	1-1/4	31.75	24.4	21.8	29.7	16.8	39.9	47.2	36.6
16UMVES-16U	1	25.40	1-5/16-12	22.0	1-3/8	34.92	1-1/2	38.10	1-1/2	38.10	31.2	26.4	35.3	16.8	47.5	50.5	43.9

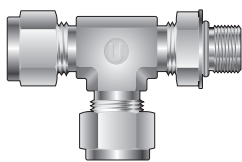

*Positionable Male
Run Tee*
UMRTS

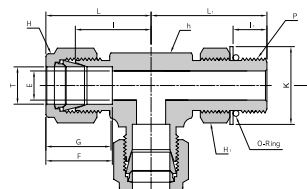

Connects Fractional Tube to SAE Straight Thread Boss

Part No.	Tube O.D. T		Straight Thread P(U)	E Min	h		H		H ₁		F	G	l	l ₁	L	L ₁	K
	in	mm			in	mm	in	mm	in	mm							
04UMRTS-04U	1/4	6.35	7/16-20	4.8	1/2	12.70	9/16	14.28	9/16	14.28	15.2	17.8	21.1	9.9	28.4	28.4	16.5
06UMRTS-06U	3/8	9.52	9/16-18	7.0	5/8	15.87	11/16	17.46	11/16	17.46	16.8	19.3	24.6	11.2	32.0	32.3	20.1
08UMRTS-08U	1/2	12.70	3/4-16	10.0	13/16	20.63	7/8	22.22	7/8	22.22	22.9	21.8	27.4	12.7	37.6	37.8	25.7
12UMRTS-12U	3/4	19.05	1-1/16-12	16.0	1-1/8	28.57	1-1/8	28.57	1-1/4	28.57	24.4	21.8	31.2	16.8	41.4	48.8	36.6
16UMRTS-16U	1	25.40	1-5/16-12	22.0	1-3/8	34.92	1-1/2	38.10	1-1/2	38.10	31.2	26.4	38.4	16.8	50.5	50.5	43.9

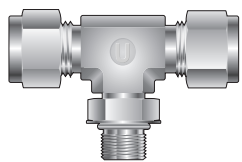

*Positionable Male
Branch Tee*
UMBTS

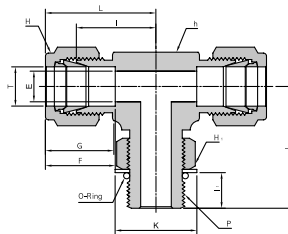

Connects Fractional Tube to SAE Straight Thread Boss

Part No.	Tube O.D. T		Straight Thread P(U)	E Min	h		H		H ₁		F	G	l	l ₁	L	L ₁	K
	in	mm			in	mm	in	mm	in	mm							
04UMBTS-04U	1/4	6.35	7/16-20	4.8	1/2	12.70	9/16	14.28	9/16	14.28	15.2	17.8	21.1	9.9	28.4	28.4	16.5
06UMBTS-06U	3/8	9.52	9/16-18	7.0	5/8	15.87	11/16	17.46	11/16	17.46	16.8	19.3	24.6	11.2	32.0	32.3	20.1
08UMBTS-08U	1/2	12.70	3/4-16	10.0	13/16	20.63	7/8	22.22	7/8	22.22	22.9	21.8	27.4	12.7	37.6	37.8	25.7
12UMBTS-12U	3/4	19.05	1-1/16-12	16.0	1-1/8	26.98	1-1/8	28.57	1-1/4	31.75	24.4	21.8	31.2	16.8	41.4	48.8	36.6
16UMBTS-16U	1	25.40	1-5/16-12	22.0	1-3/8	34.92	1-1/2	38.10	1-1/2	38.10	31.2	26.4	38.4	16.8	50.5	53.6	43.9

Note : Dimensions are reference only, subject to change without prior notice. F,G and L are typical finger tight.

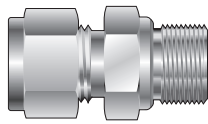

*O-Seal Straight
Thread Connector*
UMOS

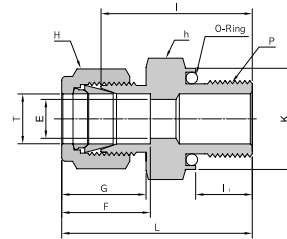

Connects Fractional Tube to Female Straight Thread

Part No.	Tube O.D. T		Straight Thread P(U)	E Min	h		H		F	G	l	l ₁	L
	in	mm			in	mm	in	mm					
02UMOS-02U	1/8	3.17	5/16-24	2.3	9/16	14.28	7/16	11.11	12.7	15.2	26.2	8.6	32.8
03UMOS-03U	3/16	4.76	3/8-24	3.0	5/8	15.87	1/2	12.70	13.7	16.0	27.7	9.7	34.3
04UMOS-04U	1/4	6.35	7/16-20	4.8	3/4	19.05	9/16	14.28	15.2	17.8	31.0	10.4	38.4
05UMOS-05U	5/16	7.93	1/2-20	6.4	7/8	22.22	5/8	15.87	16.3	18.5	33.3	11.2	40.6
06UMOS-06U	3/8	9.52	9/16-18	7.0	15/16	23.81	11/16	17.46	16.8	19.3	35.1	11.9	42.4
08UMOS-08U	1/2	12.70	3/4-16	10.0	1-1/8	28.57	7/8	22.22	22.9	21.8	35.8	11.9	46.0
12UMOS-12U	3/4	19.05	1-1/16-12	16.0	1-1/2	38.10	1-1/8	28.57	24.4	21.8	42.2	14.2	52.3
16UMOS-16U	1	25.40	1-5/16-12	22.0	1-3/4	44.45	1-1/2	38.10	31.2	26.4	46.0	14.2	58.2

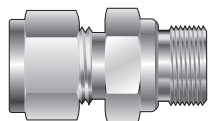

*O-Seal Pipe
Thread Connector*
UMOP

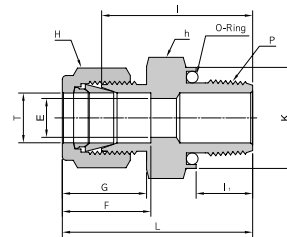

Connects Fractional Tube to Female NPT Thread

Part No.	Tube O.D. T		P (NPT)	E Min	h		H		F	G	l	l ₁	L
	in	mm			in	mm	in	mm					
02UMOP-02N	1/8	3.17	1/8	2.3	3/4	19.05	7/16	11.11	12.7	15.2	26.2	7.1	32.8
04UMOP-02N	1/4	6.35	1/8	4.8	3/4	19.05	9/16	14.28	15.2	17.8	27.7	7.1	35.1
04UMOP-04N	1/4	6.35	1/4	4.8	15/16	23.81	9/16	14.28	15.2	17.8	31.0	9.7	38.4
06UMOP-04N	3/8	9.52	1/4	7.0	15/16	23.81	11/16	17.46	16.8	19.3	32.5	9.7	39.9
06UMOP-06N	3/8	9.52	3/8	7.0	1-1/8	28.57	11/16	17.46	16.8	19.3	34.0	10.4	41.4
06UMOP-08N	3/8	9.52	1/2	7.0	1-5/16	33.33	11/16	17.46	16.8	19.3	39.6	13.5	47.0
08UMOP-08N	1/2	12.70	1/2	10.0	1-5/16	33.33	7/8	22.22	22.9	21.8	39.6	13.5	49.8

Female ISO Tapered thread are available for all fractional UMOP. Add "R" as a suffix instead of "N".

Note : Dimensions are reference only, subject to change without prior notice. F, G and L are typical finger tight.

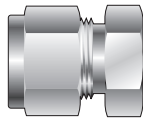

Tube Cap
UC

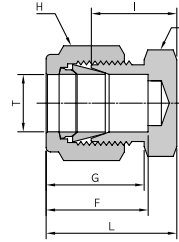

Connects Fractional Tube

Part No.	Tube O.D. T		h		H		F	G	l	L
	in	mm	in	mm	in	mm				
02UC	1/8	3.17	7/16	11.11	7/16	11.11	12.7	15.2	13.5	20.1
03UC	3/16	4.76	7/16	11.11	1/2	12.70	13.7	16.0	14.7	21.3
04UC	1/4	6.35	1/2	12.70	9/16	14.28	15.2	17.8	16.0	23.3
05UC	5/16	7.93	9/16	14.28	5/8	15.87	16.3	18.5	17.0	24.4
06UC	3/8	9.52	5/8	15.87	11/16	17.46	16.8	19.3	18.3	25.7
08UC	1/2	12.70	13/16	20.63	7/8	22.22	22.9	21.8	19.1	29.2
10UC	5/8	15.87	15/16	23.81	1	25.40	24.4	21.8	19.8	30.0
12UC	3/4	19.05	1-1/16	26.98	1-1/8	28.57	24.4	21.8	21.3	31.5
14UC	7/8	22.22	1-3/16	30.16	1-1/4	31.75	25.9	21.8	23.9	34.0
16UC	1	25.40	1-3/8	34.92	1-1/2	38.10	31.2	26.4	26.2	38.4

Connects Metric Tube

Part No.	Tube O.D. T(mm)	h	H	F	G	l	L
M03UC	3	11.11	11.11	12.9	15.3	13.5	20.1
M04UC	4	11.11	12.70	13.7	16.1	14.7	21.3
M06UC	6	14.28	14.28	15.3	17.7	15.7	23.1
M08UC	8	15.87	15.87	16.2	18.6	17.0	24.5
M10UC	10	17.46	19.05	17.2	19.5	19.0	26.6
M12UC	12	22.22	22.22	22.8	22.0	19.0	29.1
M15UC	15	23.81	25.40	24.4	22.0	19.8	29.9
M16UC	16	23.81	25.40	24.4	22.0	19.8	29.9
M18UC	18	26.98	30.16	24.4	22.0	21.3	31.4
M20UC	20	30.16	31.75	26.0	22.0	23.9	34.0
M22UC	22	30.16	31.75	26.0	22.0	23.9	34.0
M25UC	25	34.92	38.10	31.3	26.5	26.2	38.5

Note : Dimensions are reference only, subject to change without prior notice. F,G and L are typical finger tight.

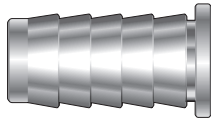

Tube Inset
UI

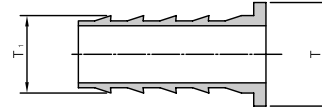

Connects Fractional Tube

Part No.	Tube O.D.		Tube I.D.	
	T		T ₁	
	in	mm	in	mm
03UI-02	3/16	4.76	1/8	3.17
04UI-02	1/4	6.35	1/8	3.17
04UI-03	1/4	6.35	3/16	4.76
05UI-02	5/16	7.93	1/8	3.17
05UI-03	5/16	7.93	3/16	4.76
05UI-04	5/16	7.93	1/4	6.35
06UI-03	3/8	9.52	3/16	4.76
06UI-04	3/8	9.52	1/4	6.35
08UI-04	1/2	12.70	1/4	6.35
08UI-06	1/2	12.70	3/8	9.52
10UI-06	5/8	15.87	3/8	9.52
10UI-08	5/8	15.87	1/2	12.70
12UI-08	3/4	19.05	1/2	12.70
12UI-10	3/4	19.05	5/8	15.87
16UI-12	1	25.40	3/4	19.05

Connects Metric Tube

Part No.	Tube O.D.	Tube I.D.
	T	T ₁
M06UI-M04	6	4
M08UI-M06	8	6
M10UI-M08	10	8
M12UI-M08	12	8
M12UI-M10	12	10

Note : Dimensions are reference only, subject to change without prior notice. F, G and L are typical finger tight.

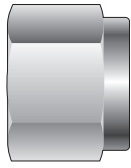

Nut
UN

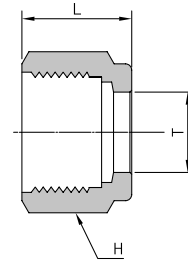

Connects Fractional Tube

Part No.	Tube O.D. T		H		L
	in	mm	in	mm	
02UN	1/8	3.17	7/16	11.11	11.9
03UN	3/16	4.76	1/2	12.70	11.9
04UN	1/4	6.35	9/16	14.28	12.7
05UN	5/8	7.93	5/8	15.87	13.4
06UN	3/8	9.52	11/16	17.46	14.2
08UN	1/2	12.70	7/8	22.22	17.5
10UN	5/8	15.87	1	25.40	17.5
12UN	3/4	19.05	1-1/8	28.57	17.5
14UN	7/8	22.22	1-1/4	31.75	17.5
16UN	1	25.40	1-1/2	38.10	20.6

Connects Metric Tube

Part No.	Tube O.D. T(mm)	H	L
M03UN	3	11.11	11.9
M04UN	4	12.70	11.9
M06UN	6	14.28	12.7
M08UN	8	15.87	13.4
M10UN	10	19.05	15.1
M12UN	12	22.22	17.5
M15UN	15	25.40	17.5
M16UN	16	25.40	17.5
M18UN	18	30.16	17.5
M20UN	20	31.75	17.5
M22UN	22	31.75	17.5
M25UN	25	38.10	20.6

Note : Dimensions are reference only, subject to change without prior notice. F,G and L are typical finger tight.

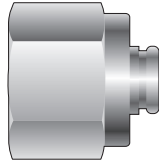

Tube Plug
UP

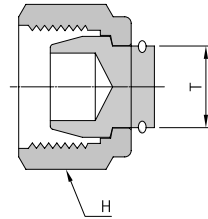

Connects Fractional Tube

Part No.	Tube O.D. T		H	
	in	mm	in	mm
02UP	1/8	3.17	7/16	11.11
03UP	3/16	4.76	1/2	12.70
04UP	1/4	6.35	9/16	14.28
05UP	5/16	7.93	5/8	15.87
06UP	3/8	9.52	11/16	17.46
08UP	1/2	12.70	7/8	22.22
10UP	5/8	15.87	1	25.40
12UP	3/4	19.05	1-1/8	28.57
14UP	7/8	22.22	1-1/4	31.75
16UP	1	25.40	1-1/2	38.10

Connects Metric Tube

Part No.	Tube O.D. T(mm)	H
M3UP	3	11.11
M4UP	4	12.70
M6UP	6	14.28
M8UP	8	15.87
M10UP	10	19.05
M12UP	12	22.22
M15UP	15	25.40
M16UP	16	25.40
M18UP	18	30.16
M20UP	20	31.75
M22UP	22	31.75
M25UP	25	38.10

Note : Dimensions are reference only, subject to change without prior notice. F,G and L are typical finger tight.



Front Ferrule
UFF

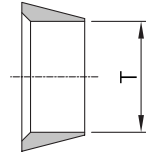

Connects Fractional Tube

Part No.	Tube O.D. T	
	in	mm
02UFF	1-8	3.17
03UFF	3/16	4.76
04UFF	1/4	6.35
05UFF	5/16	7.93
06UFF	3/8	9.52
08UFF	1/2	12.70
10UFF	5/8	15.87
12UFF	3/4	19.05
14UFF	7/8	22.22
16UFF	1	25.40

Connects Metric Tube

Part No.	Tube O.D. T (mm)
M03UFF	3
M04UFF	4
M06UFF	6
M08UFF	8
M10UFF	10
M12UFF	12
M15UFF	15
M16UFF	16
M18UFF	18
M20UFF	20
M22UFF	22
M25UFF	25



Back Ferrule
UBF

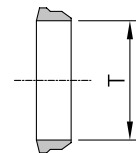

Connects Fractional Tube

Part No.	Tube O.D. T	
	in	mm
02UBF	1/8	3.17
03UBF	3/16	4.76
04UBF	1/4	6.35
05UBF	5/16	7.93
06UBF	3/8	9.52
08UBF	1/2	12.70
10UBF	5/8	15.87
12UBF	3/4	19.05
14UBF	7/8	22.22
16UBF	1	25.40

Connects Metric Tube

Part No.	Tube O.D. T (mm)
M03UBF	3
M04UBF	4
M06UBF	6
M08UBF	8
M10UBF	10
M12UBF	12
M15UBF	15
M16UBF	16
M18UBF	18
M20UBF	20
M22UBF	22
M25UBF	25

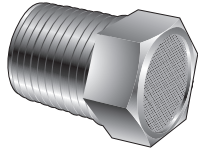

Vent Protector
UVP

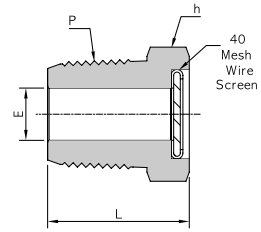

Connects Female ISO NPT Thread

Part No.	E	H		L
		in	mm	
UVP-04N	7.0	9/16	14.28	19.8
UVP-06N	10.0	11/16	17.46	20.5
UVP-08N	12.0	7/8	22.22	26.2
UVP-12N	18.0	1-1/16	26.98	27.0

Note : Dimensions are reference only, subject to change without prior notice.

LINE UP

Tube Fittings



Uni-primet Weld & Face Seal Fittings



PTFE Fittings



Diaphragm / Bellows Valve



Needle Valves



Ball Valves



Hex Ball Valves



Check Valves



Manifold Valves



Filters



TUBE/PIPE Clean BEND Fittings



Tubes AP/BA/EP





유니온금속공업(주)
UNION METAL INDUSTRIAL CO.,LTD.

본사 및 공장

인천광역시 남동구 고잔동 725-13번지
남동공단 152블럭 12롯트
TEL:(032)822-6600(대) FAX:(032)821-6604
<http://www.unilok.com>
E-mail : unilok@unilok.com

서울직매장

서울특별시 구로구 구로동 604-1
구로기계공구상가 D-31-110호
TEL:(02)2676-6673(대) FAX:(02)2679-6673

Head Office and Factory

152 Block-12Lot, Namdong Industrial Complex,
725-13, Gojan-Dong, Namdong-Gu, Incheon,
KOREA.
TEL:+82-32-822-6600 FAX:+82-32-821-6604
<http://www.unilok.com>
E-mail:unilok@unilok.com

Seoul Office

D-31-110, Guro Tools Center.
604-1, Guro-Dong, Guro-Gu, Seoul, KOREA.
TEL:+82-2-2676-6673 FAX:+82-2-2679-6673