

Instrumentation Check Valves

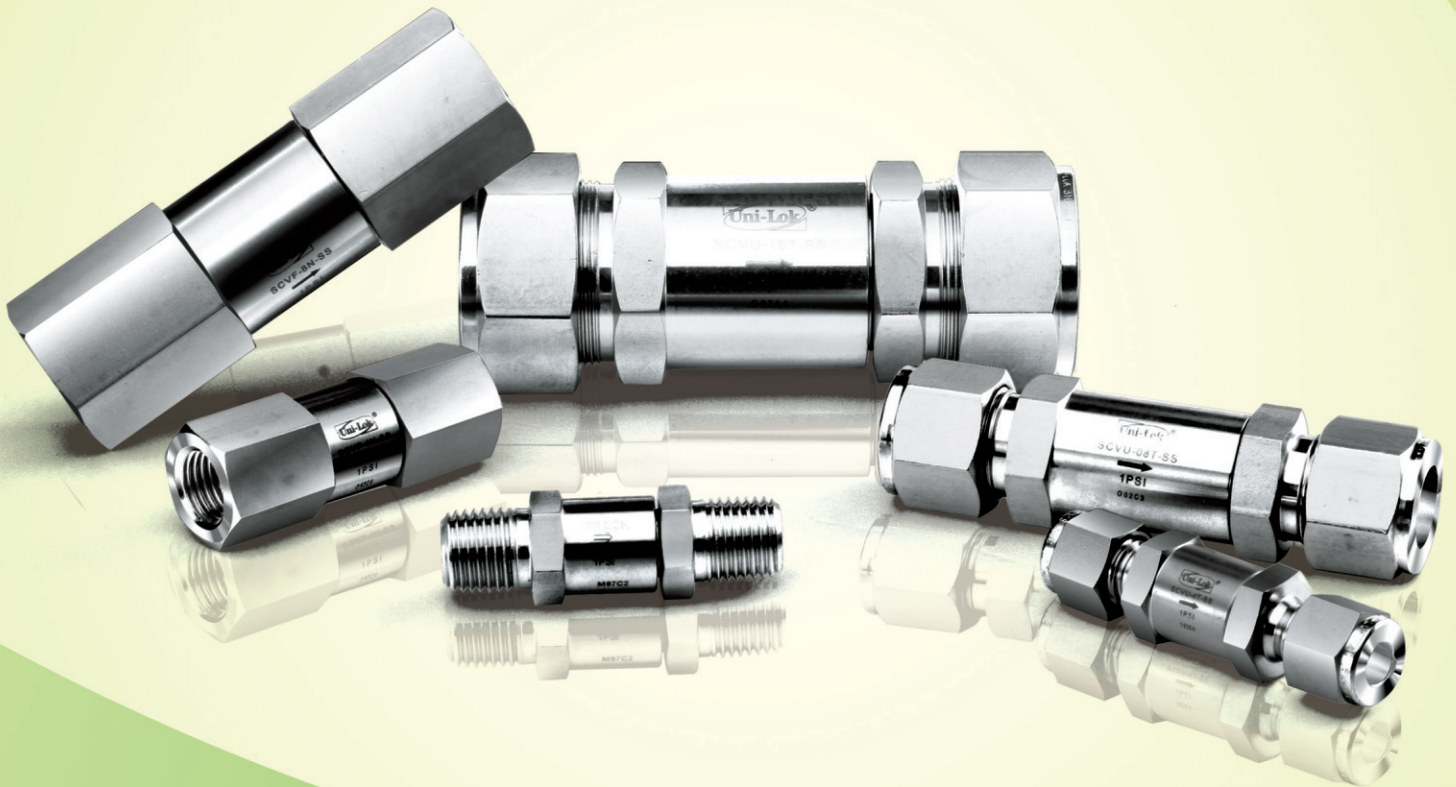

Features

- Pressure rating up to 3000 psi(206 bar) @21 °C(70°F)
- Temperature rating from -20°C(-4°F) to +190°C(374°F) with Viton® seal
- Fixed cracking pressure
- 316 Stainless steel
- Wide choices of end connections : Uni-Lok Tube Fittings, Male & Female NPT or ISO 7/1 thread
Viton® is the trade mark of DuPont.

Testing

- Every valve is 100% factory tested with nitrogen for cracking and reseal performance.
- Other optional tests are available upon request.

Safe Valve Selection

- When selecting a valve, the total system design must be considered to ensure safe, trouble-free performance.
Valve function, materials compatibility, adequate ratings, proper installation, operation and maintenance are the responsibility of the system designer or user.

How to Order

08 - SCV U - 08 N - 01

Tube O.D.

Tube O.D. Designations

| Tube O.D. | inch | 1/4 | 3/8 | 1/2 | 3/4 | 1 |
|-------------|------|------|------|-------|-------|-------|
| | mm | 6.35 | 9.52 | 12.70 | 19.05 | 25.04 |
| Designation | | 04 | 06 | 08 | 12 | 16 |

| Tube O.D. | 6 | 8 | 10 | 12 | 20 | 25 |
|-------------|-----|-----|-----|-----|-----|-----|
| Designation | M06 | M08 | M10 | M12 | M20 | M25 |

Check Valve

End Connection Type

U : Uni-Lok Tube Fittings
F : Female Thread
M : Male Thread

Pipe Size

Pipe Size Designations

| Nom. Size | 1/8 | 1/4 | 3/8 | 1/2 | 3/4 | 1 |
|-------------|-----|-----|-----|-----|-----|----|
| Designation | 02 | 04 | 06 | 08 | 12 | 16 |

Thread Type

N : NPT
R : PT(ISO 7/1)

Cracking Pressure

Cracking Pressure Designations

| 1/3psi | 1psi | 3psi | 10psi | 25psi |
|--------|------|------|-------|-------|
| 1/3 | 01 | 03 | 10 | 25 |

Example;

08-SCVU-01 : Check Valve, 1/2"OD, 1psi
SCVF-04N-25 : Check Valve, 1/4" Female NPT, 25psi

SCVU, SCVF, SCVM Series

Materials of Construction

| No. | Description | 316SS Valve |
|-----|-------------|--------------------|
| 1 | Inlet Body | 316SS |
| 2 | Outlet Body | 316SS |
| 3 | O-Ring | Viton |
| 4 | Gasket | 304SS (12T,16T) |
| 5 | Poppet | 316SS |
| 6 | Spring | 302SS |

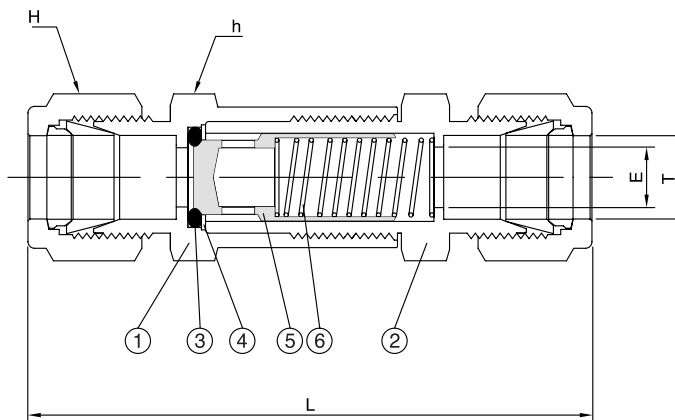

Table of Dimension

SCVU Series

Unit : mm

| Part No. | Applicable Tube | | E | L | h | | H | |
|----------|-----------------|-------|------|-------|-------|-------|-------|-------|
| | Nom | O.D | | | in | mm | in | mm |
| 04-SCVU | 1/4 | 6.35 | 4.8 | 61.2 | 5/8 | 15.87 | 9/16 | 14.28 |
| 06-SCVU | 3/8 | 9.52 | 7.0 | 82.7 | 7/8 | 22.22 | 11/16 | 17.46 |
| 08-SCVU | 1/2 | 12.70 | 10.0 | 87.3 | 7/8 | 22.22 | 7/8 | 22.22 |
| 12-SCVU | 3/4 | 19.05 | 16.0 | 91.6 | 1-1/4 | 31.75 | 1-1/8 | 28.57 |
| 16-SCVU | 1 | 25.40 | 19.5 | 120.0 | 1-3/8 | 34.92 | 1-1/2 | 38.10 |
| M06-SCVU | 6 | 6 | 4.8 | 61.2 | | 15.87 | | 14.28 |
| M08-SCVU | 8 | 8 | 6.4 | 61.8 | | 15.87 | | 15.87 |
| M10-SCVU | 10 | 10 | 8.0 | 81.7 | | 22.22 | | 19.05 |
| M12-SCVU | 12 | 12 | 9.5 | 87.3 | | 22.22 | | 22.22 |
| M25-SCVU | 25 | 25 | 19.5 | 120.0 | | 34.92 | | 38.10 |

SCVF, SCVM Series

Unit : mm

| Part No. | P (NPT) | E | L | h | |
|----------|------------|------|-------|-------|-------|
| | | | | in | mm |
| SCVF-04N | 1/4 | 4.8 | 54.8 | 5/8 | 15.87 |
| SCVF-06N | 3/8 | 7.0 | 76.2 | 7/8 | 22.22 |
| SCVF-08N | 1/2 | 7.0 | 90.5 | 7/8 | 22.22 |
| SCVF-12N | 3/4 | 16.0 | 87.5 | 1-1/4 | 31.75 |
| SCVF-16N | 1 | 19.5 | 123.0 | 1-3/8 | 34.92 |
| SCVM-04N | 1/4 | 4.8 | 53.2 | 5/8 | 15.87 |
| SCVM-06N | 3/8 | 7.0 | 70.6 | 7/8 | 22.22 |
| SCVM-08N | 1/2 | 7.0 | 80.2 | 7/8 | 22.22 |
| SCVM-12N | 3/4 | 16.0 | 86.0 | 1-1/4 | 31.75 |
| SCVM-16N | 1 | 19.5 | 115.0 | 1-3/8 | 34.92 |

Male ISO Tapered Threads are available for all SCVF, SCVM Series. Add "R" as a suffix instead of "N"

Note : Dimensions are reference only, subject to change without prior notice.



유니온금속공업(주)
UNION METAL INDUSTRIAL CO.,LTD.

본사 및 공장

인천광역시 남동구 고잔동 725-13번지
남동공단 152블럭 12롯트
TEL:(032)822-6600(대) FAX:(032)821-6604
<http://www.unilok.com>
E-mail : unilok@unilok.com

서울직매장

서울특별시 구로구 구로동 604-1
구로기계공구상가 D-31-110호
TEL:(02)2676-6673(대) FAX:(02)2679-6673

Head Office and Factory

152 Block-12Lot, Namdong Industrial Complex,
725-13, Gojan-Dong, Namdong-Gu, Incheon,
KOREA.
TEL:+82-32-822-6600 FAX:+82-32-821-6604
<http://www.unilok.com>
E-mail:unilok@unilok.com

Seoul Office

D-31-110, Guro Tools Center,
604-1, Guro-Dong, Guro-Gu, Seoul, KOREA.
TEL:+82-2-2676-6673 FAX:+82-2-2679-6673